

# tenditore petband® / petband® tensioner / tendeur pour petband®



---

**libretto d'istruzione - uso /**

**instruction manual - use / notice d'instructions - mode d'emploi**

**modello / model / modèle: PB 200 CH**

---

CE

## Field of Application for the PB 200 CH tool

Joint system strapping tool PB 200 CH is suitable exclusively for strapping all kinds of goods to be packaged, for securing cargo load units respectively using conventional cord and composite strap.

## Warning and Safety Recommendations



Use safety glasses with lateral guards and protective gloves during cutting operations while working with strapping tools for cord and composite strap.



Do not put your hand or any other parts of your body between the strap and the piece to be packaged while operating the strapping tool.



The strap may tear while tensioning! Do not stand with-in the flight of the strap.



Hold the upper part in your hand while you cut the strap, and place yourself outside this range.  
**Caution:** The lower strap end will spring up; Use safety strap shears!



Use only original central spare parts.

## Suitable Cord and Composite Strap and Buckles

Use commercial size **textile and composite strap** 0.5 to 2.4 mm thick and 50 mm (2") max. wide exclusively.

Use commercial type **locking buckles** of suitable size only. The buckles must be used together with the proper textile or composite strap as released by the strap producer.

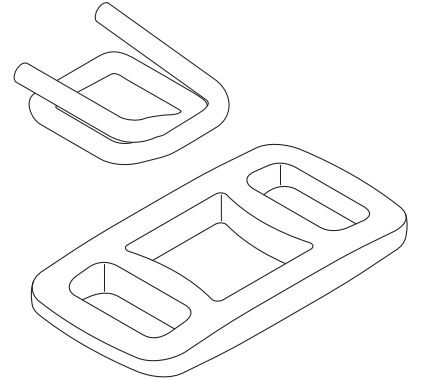

# Mounting the Locking Buckle

Depending on the type of buckle, different methods can be used to thread the cord and composite strap into the locking buckle.

**Option I** can be used for buckles with open ends. **Option II** can be used for closed buckles.

Decisive for the method applied for strap mounting are the details furnished by the producer of the locking buckle used in combination with the cord or composite strap applied.

## Variant I

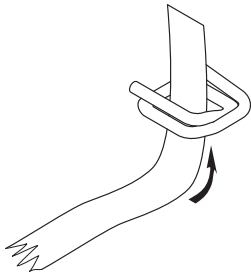

### 1. Placing strap end into buckle

The locking buckle ends must point upward and away from the operator. Run the strap end from the bottom through the buckle opening.

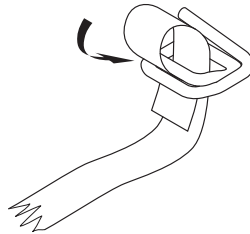

### 2. Inserting the strap end into the buckle

Run the strap end around the buckle end located left from the operator and lead it through the distance between the buckle end and lower located buckle winding.

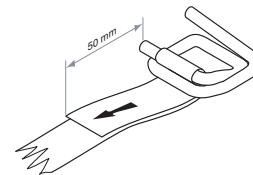

### 3. Termination of strap end mounting

Lead strap end through the buckle until it protrudes over the buckle 50 mm minimum. Now run the strap around the package or around the cargo unit to be secured.

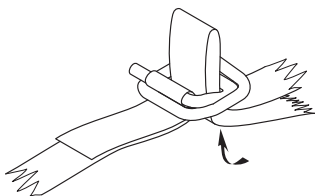

### 4. Inserting strap loop into buckle

Bend over strap and place bent portion from lower end through buckle opening.

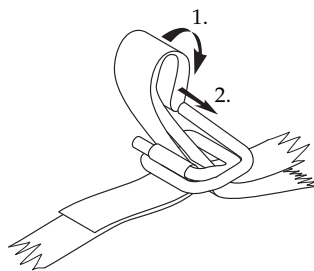

### 5. Mounting strap loop in buckle

First bend folded portion approx. 180° around the right hand buckle end and then slide it over buckle end.

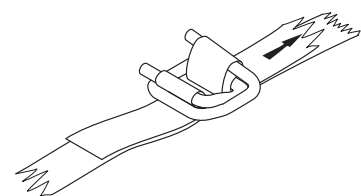

### 6. Tightening the strap

Manually tighten the upper strap portion retaining the lower portion of the strap ensuring that the buckle is not displaced.

## Variant II

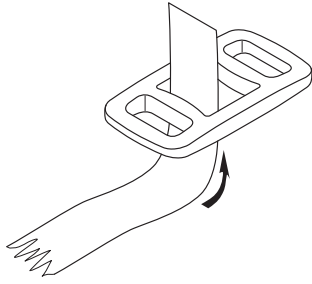

### 1. Placing the first strap end into the buckle

Run the first strap end from below through the middle buckle opening.

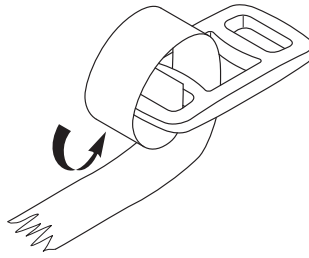

### 2. Inserting the strap end - first step

Run the strap end from below around the buckle opening located left of the operator.

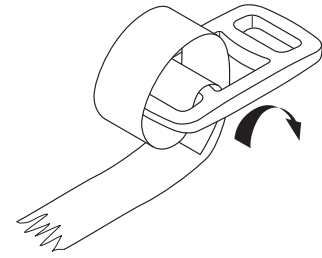

### 3. Inserting the strap end - second step

Now push the strap end from above through the middle opening.

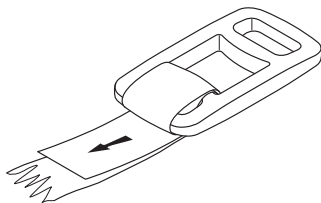

### 4. Tightening the strap

Pull the strap leaving the lock-ing buckle so that strap loop closes around the buckle.

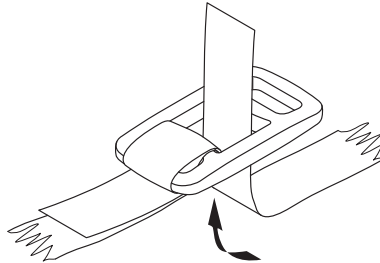

### 5. Placing the second strap end into the buckle

Run the strap around the pack-age or item to be secured and place the second strap end from below into the middle buckle opening.

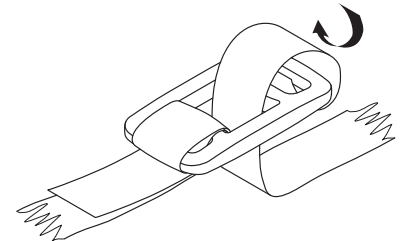

### 6. Inserting the strap end - first step

Run the strap end from below around the buckle opening located right of the operator.

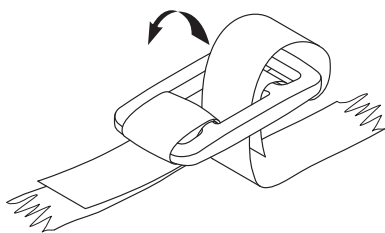

### 7. Inserting the strap end - second step

Now push the strap end from above through the middle opening.

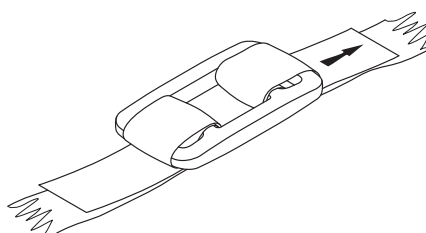

### 8. Tightening the strap

Pull the strap leaving the lock-ing buckle so that strap loop closes around the buckle.

# Operation

of joint system strapping tool PB 200 CH

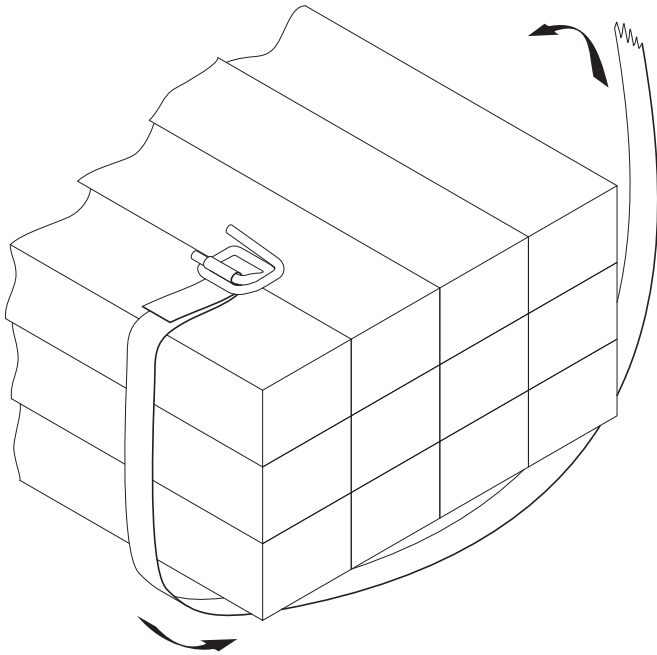

## 1. Mounting strap in locking buckle

First, the end of the cord or composite strap should be mounted to the buckle end left hand viewing from the user's side in accordance with Variant I or II

Then run the strap around the package or cargo unit to be secured.

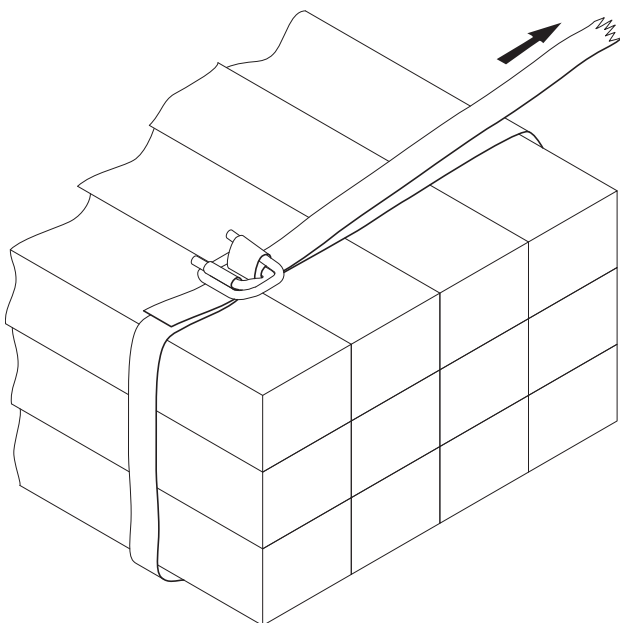

## 2. Sealing locking loop

Run strap according to Variant I or II through the locking buckle at the right hand buckle end.

Tighten strap by pulling at the upper strap end and simultaneously manually arresting the lower strap end.

Windlass

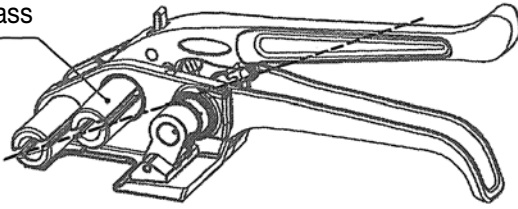

### 3. Adjust windlass

Adjust windlass clockwise or anti-clockwise so the slot of windlass and cutter are in line.

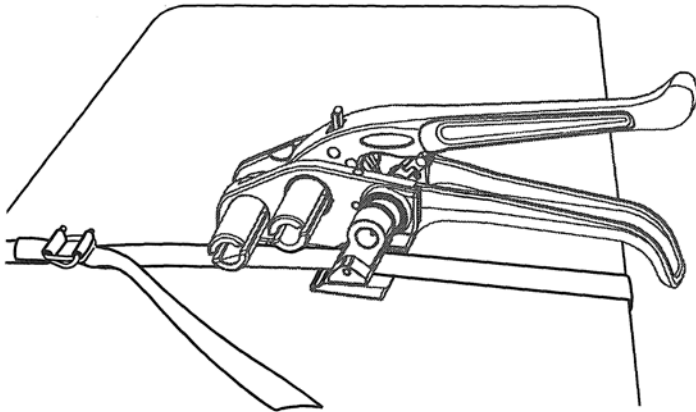

### 4. Inserting the strap

Press the handle to lift the leg so the strap can be put under the gripper as shown.

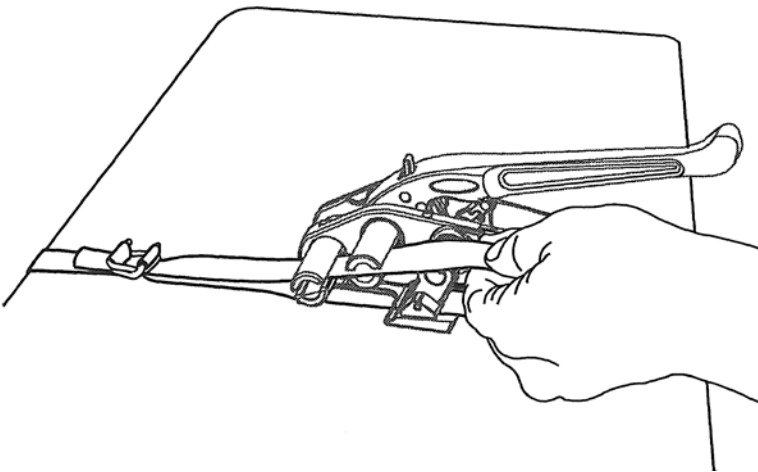

### 4.a Inserting the strap

Slide the upper strap through the slot of cutter and windlass.

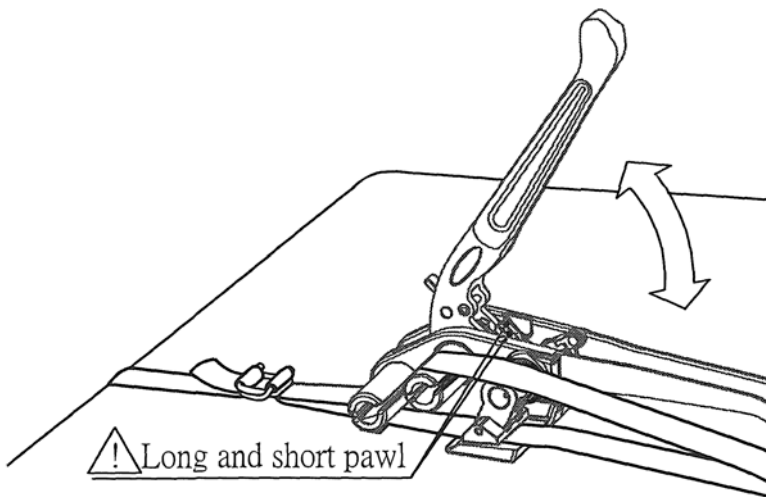

## 5. Strap tensioning

Hold the tool and strap with your left hand and move the handle forward and backward until the strap is tensioned.

! When tensioning the strap, do not rotate the handle to the point where it will touch the long and short pawl. This will cause a sudden cut and release to the strap.!

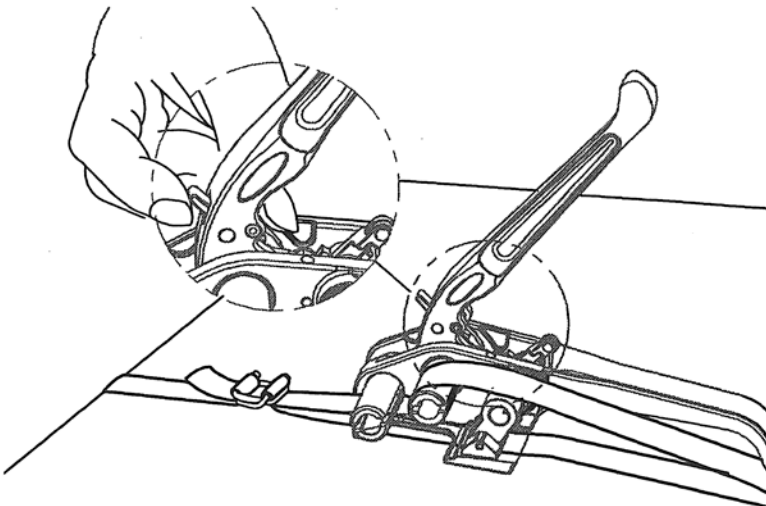

## 6. apply more tension

When more tension is needed but the handle is in an uneasy position and hard to apply tension, press the handle release pawl down to release the handle and reposition the handle to apply more tension.

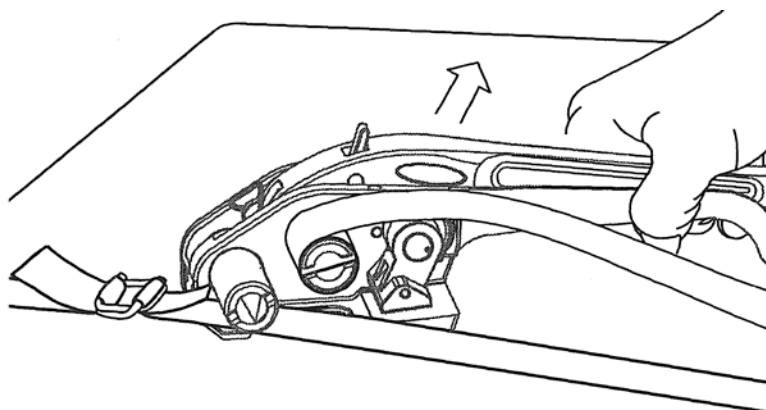

## 6. Releasing the tool

At the end of the sealing operation, swing the lever back.

Press the tensioning lever down to cut the strap, thus releasing the strapping tool from the unit to be packaged or item to be secured. Move the tool to the right side away from the package.

The strap end remaining on the winding shaft may be removed without any tool.





# spare parts table

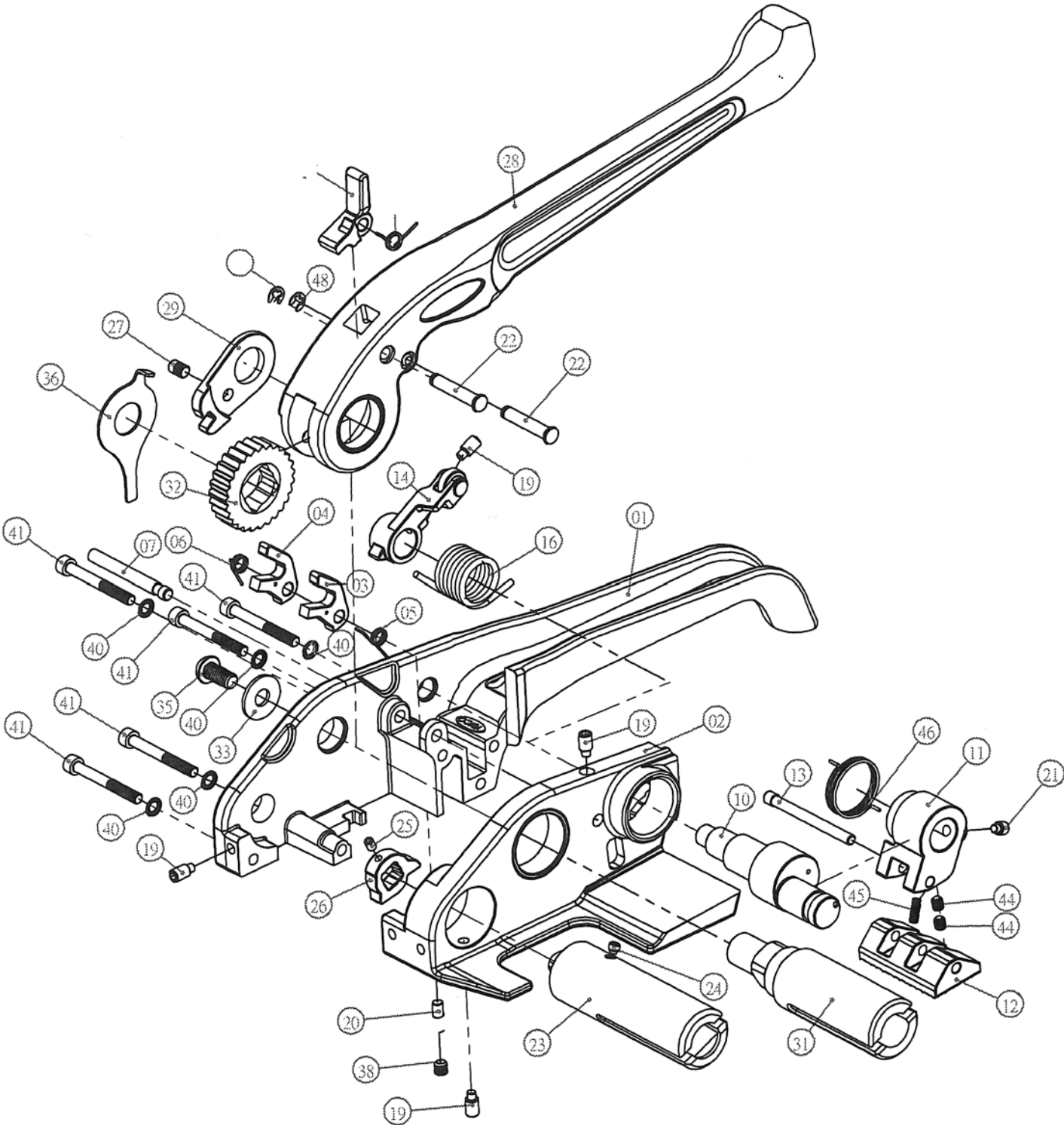

# spare parts list

for PB 200 CH strapping tool

Part no.	Description	Quantity
01	Aluminium Base	1
02	Steel Base	1
03	Long Pawl	1
04	Short Pawl	1
05	Long Pawl Spring	1
06	Short Pawl Spring	1
07	Pawl Pin	1
10	Leg Shaft	1
11	Leg	1
12	Gripper	1
13	Leg Pin	1
14	Lever Release Assembly	1
16	Main Spring	1
18	Handle Release Pawl	1
19	Set Screw	4
20	Set Screw	1
21	Set Screw	1
22	Pawl Release Pin	2
23	Cutter and Cutter Housing	1
24	Set Screw	1
25	Set Screw	1
26	Cutter Link	1
27	Nose pin	1
28	Handle	1
29	Nose Hook	1
30	Handle Pawl Spring	1
31	Windlass	1
32	Ratchet Wheel	1
33	Washer	1
35	Set Screw	1
36	Handle Plate	1
38	Set Screw	1
40	Washer	5
41	Blot Pin	5
44	Set Screw	2
45	Gripper Spring	1
46	Leg Spring	1
48	E Clip	2

**PB 200 CH strapping tool**

## PB 200 CH Maintenance

The clamp plate 12 requires daily cleaning from strap residue either by compressed air, wire brush or another suitable mechanical accessory. More frequent cleaning may be indicated depending on the strap used or frequency of application.

Otherwise the PB 200 CH strapping tool requires no service. However, for repair work the repair instructions at the end of these operating instructions should be adhered to.

During the warranty period repairs performed by unauthorised persons will cease the guarantee of the manufacturer.

## Hints for Repair

With repair work, the sliding and bearing points must be relubricated with white grease.

During the warranty period repairs performed by unauthorised persons will cease the guarantee of the manufacturer.

## Specifications

- *Length/width/height:*  
345 x 110 x 125 mm
- *Weight:*  
3,1 kg
- *Seal:*  
Friction lock with buckle
- *for cord and composite strap, buckle:*  
25 mm (1") up to 50 mm (2"), thickness 0.5 up to 2.4 mm;  
locking buckle as per recommendation of the strap manufacturer



## strapping support accessories

---

### improve productivity and efficiency

Equipment and accessories to support and facilitate strapping activities. joint system products guarantee high performance in terms of quality and durability.

### shears

---

cutter for fabric, pes and lash strap able to easily cut the strap of any size and type in all angles.

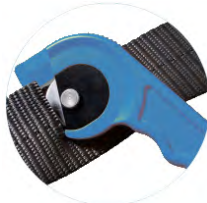

---

**joint system**

via volvera 123

10090 bruino torino italy

t +39 011 957 29 54

f +39 011 908 42 94

p iva / c f 07038280017

[info@jointsystem.com](mailto:info@jointsystem.com)