

# AUTOMATIC POLYPROPYLENE STRAPPING MACHINE



TP-601A

TP-601B

TP-601BP

TP-601AS

TP-601BS

TP-601BPS

## OPERATION MANUAL & SPARE PARTS LIST

**IMPORTANT!**  
KEEP IT WELL

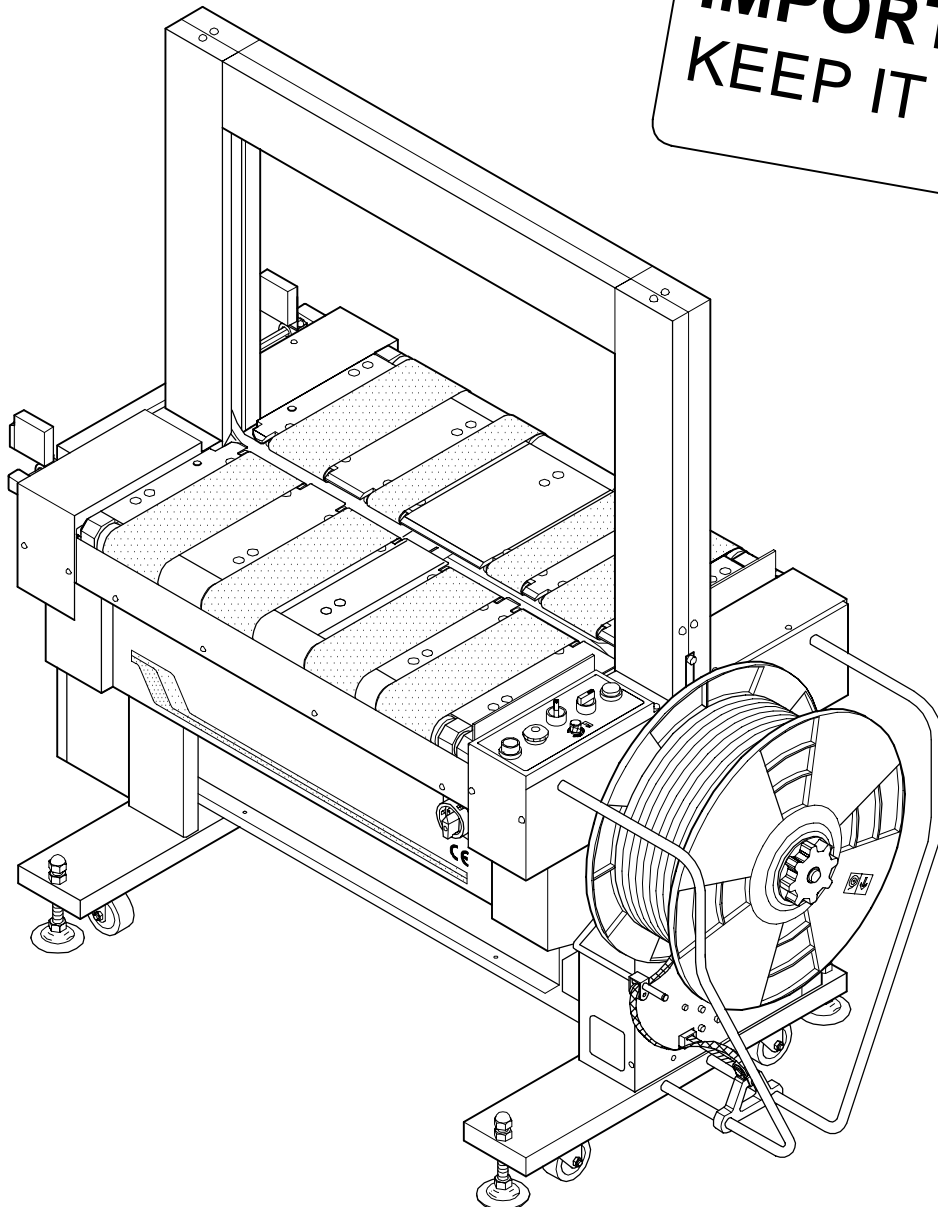

*READ ALL INSTRUCTIONS BEFORE OPERATING THIS PRODUCT*

## **Explanations for Each Model NO. :**

TP-601A : Three Phase Transit Model with Roller-Driven Table

TP-601AS : Three Phase Transit Model with Roller-Driven Table and  
Stainless Steel Frame

TP-601B : Three Phase Transit Model with Belt-Driven Table

TP-601BS : Three Phase Transit Model with Belt-Driven Table and  
Stainless Steel Frame

TP-601BP : Three Phase Transit Model with Belt-Driven Table and Press Bar

TP-601BPS : Three Phase Transit Model with Belt-Driven Table,  
Press Bar and Stainless Steel Frame

# PART I

## CONTENTS

1. Safety Instructions.....	1~2
2. Construction and Function of Units.....	3~5
3. Technical Date.....	6~8
4. Control Panel .....	9
5. Electric Unit .....	10~11
6. How to Load P.P. Strap.....	12
7. How to Operate .....	13
8. Recommendations for Trouble-free Operation.....	13
9. Adjustments.....	14~18
10. Installation of Arch Unit.....	19~20
11. Wiring Diagram .....	21~30
12. Inverter Parameters Setup.....	31
13. Troubleshooting .....	32
14. Pneumatic System Diagram.....	33
15. Installation of Cylinder Unit.....	34
16. How to connect Upstream and Downstream Machine.....	35

# 1. Safety Instructions

## (1) Before operating

- a. Please always wear proper eye protection and safety gloves before operating this machine.



Eye protection must be worn



Safety gloves must be worn

- b. Please make sure if the power voltage is correct.  
c. It can only be operated with P.P. strap; not PET strap or Polyester cord strap.

## (2) During operating

- a. The weight of package should not exceed 80kg(TP-601A) and 35kg(TP-601B/BP), and the size should not be less than 250mmx250mmx20mm.  
b. Check if the machine emits any smokes or unusual sound when it is running.  
c. Warning  
a-1. For your own safety, please read instruction manual before operating. Keep away from arch while the machine is running.  
b-2. Do not put your hands or body into the Archworking area when the machine is running.

## (3) After operating

- a. Please pull out the power plug.  
b. Please get rid of the dirt or impurity on the machine.

## (4) Signs

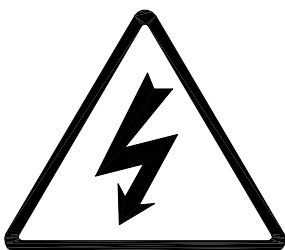

Caution, risk of electric shock



Do not touch!

**(5) Maintenance**

- a. Please turn off the power before opening the top plate.
- b. Please do not touch the heater due to the high temperature.
- c. Be careful with the heater if you open the front plate for 30mm.

**(6) Other remainders**

- a. Do not alter or bypass protective interlocks
- b. A safety manual must remain attached to the machine at all times
- c. Do not alter circuits and machine unless authorized to do so by the manufacturer.
- d. All electrical apparatus must be properly grounded.
- e. Wire the machine according to the local electrical code.

## 2. Construction and Function of Units

### a. TP-601A

#### 7 Transmission group

These rollers are driven by motor.

#### 1 Strapping head unit

This unit is the most important part of the machine for cutting and sealing of P.P. strap.

#### 2 Bandway unit

This is the arch track through which P.P. strap forwards or reverses.

#### 5 Body unit

#### 4 Reel unit

Holds the strap coil.  
(If strap core is 230/280mm, you can take off the center drum to have core size 200mm.)

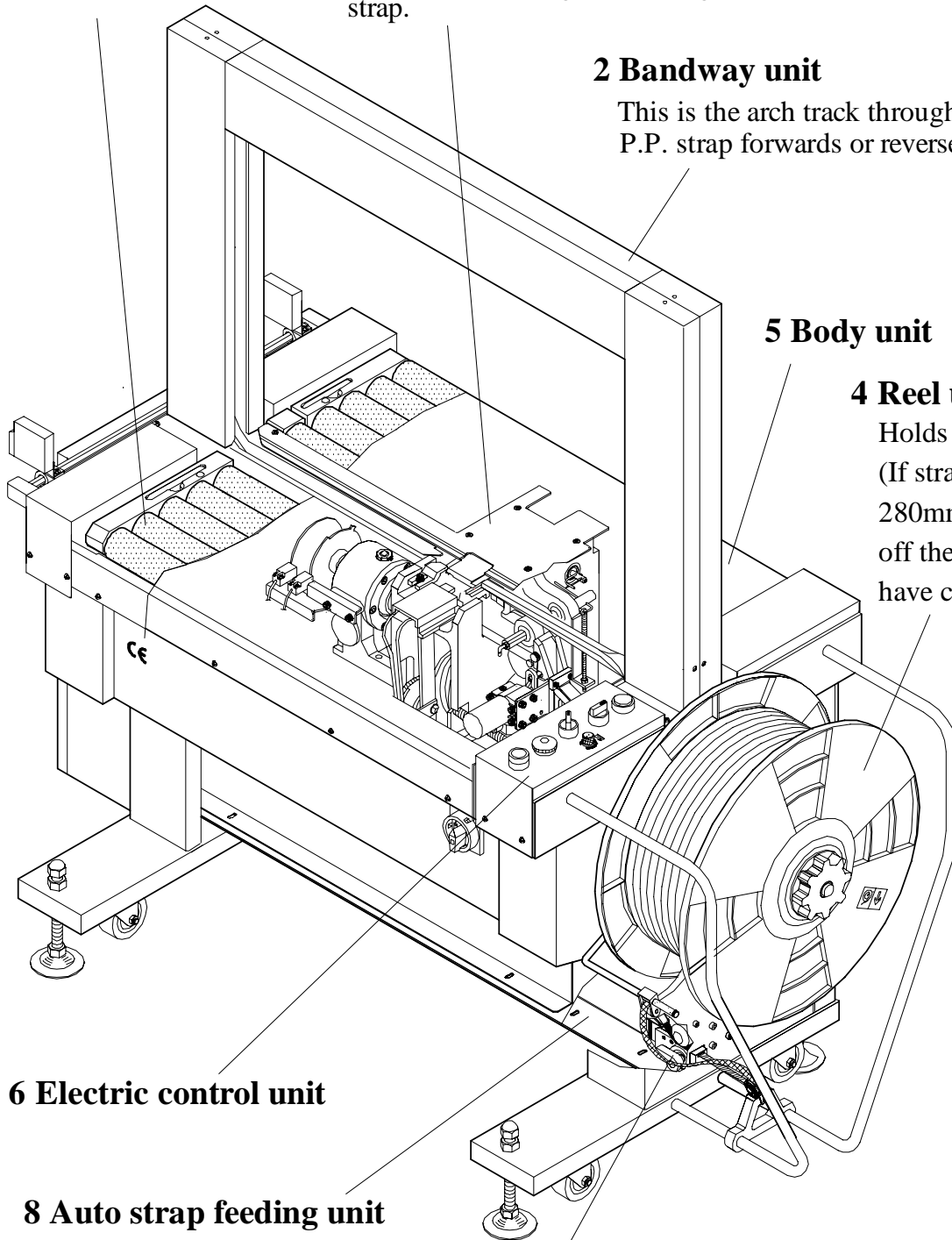

#### 6 Electric control unit

#### 8 Auto strap feeding unit

#### 3 Accumulator unit

This unit accumulates the quantity of strap required for smooth feeding into the chute track.

**b. TP-601B**

**1 Strapping head unit**

This unit is the most important part of the machine for cutting and sealing of P.P. strap.

**2 Bandway unit**

This is the arch track through which P.P. strap forwards or reverses.

**5 Body unit**

**4 Reel unit**

Holds the strap coil.  
(If strap core is 230/280mm, you can take off the center drum to have core size 200mm.)

**3 Trassmission group**

These belts are driven by motor.

**6 Electric control unit**

**8 Auto strap feeding unit**

**3 Accumulator unit**

This unit accumulates the quantity of strap required for smooth feeding into the chute track.

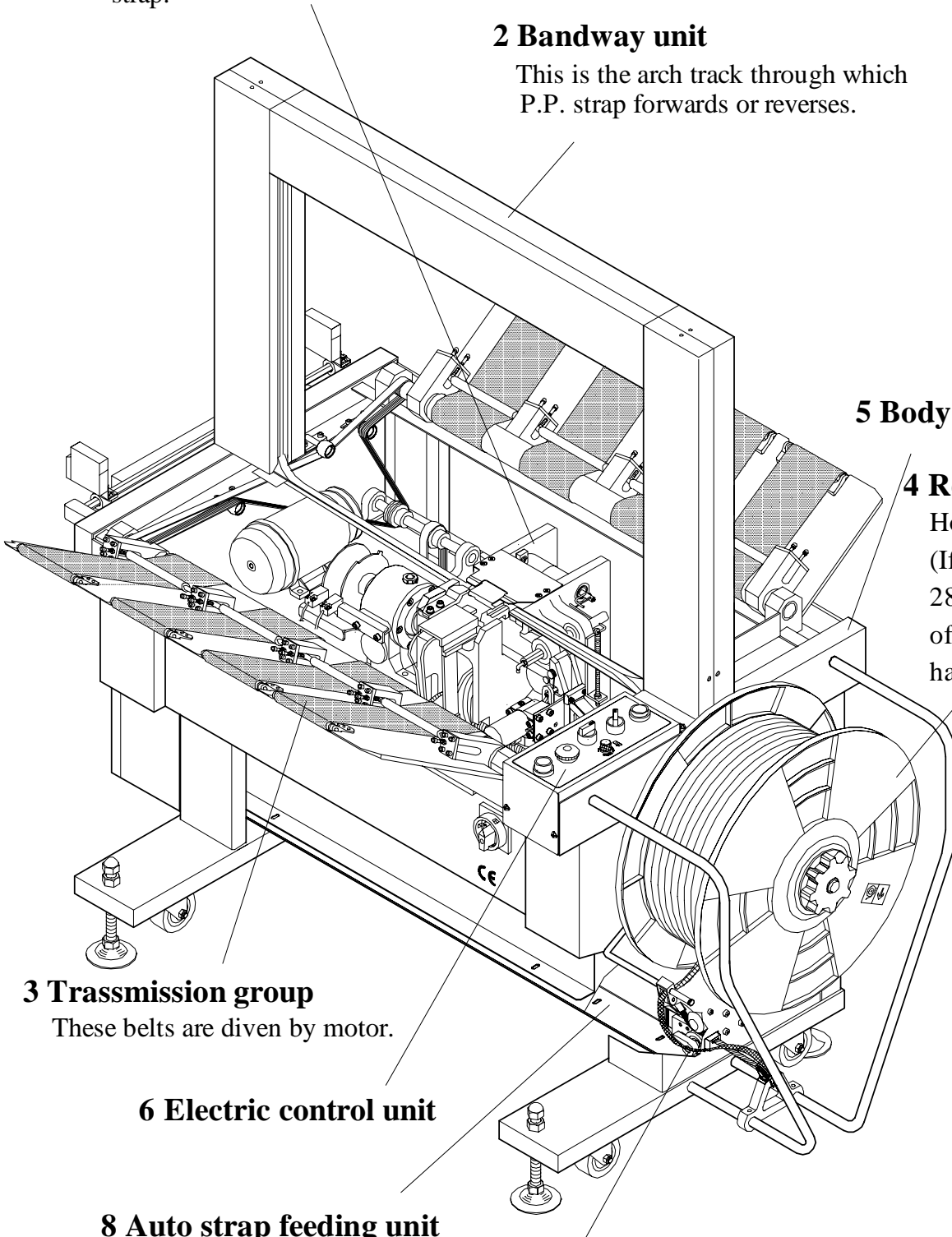

## c. TP-601BP

### 1 Strapping head unit

This unit is the most important part of the machine for cutting and sealing of P.P. strap.

### 9 Pneumatic unit

### 2 Bandway unit

This is the arch track through which P.P. strap forwards or reverses.

### 5 Body unit

### 4 Reel unit

Holds the strap coil.  
(If strap core is 230/280mm, you can take off the center drum to have core size 200mm.)

### 7 Transmission unit

### 6 Electric control unit

### 8 Auto strap feeding unit

### 3 Accumulator unit

This unit accumulates the quantity of strap required for smooth feeding into the chute track.

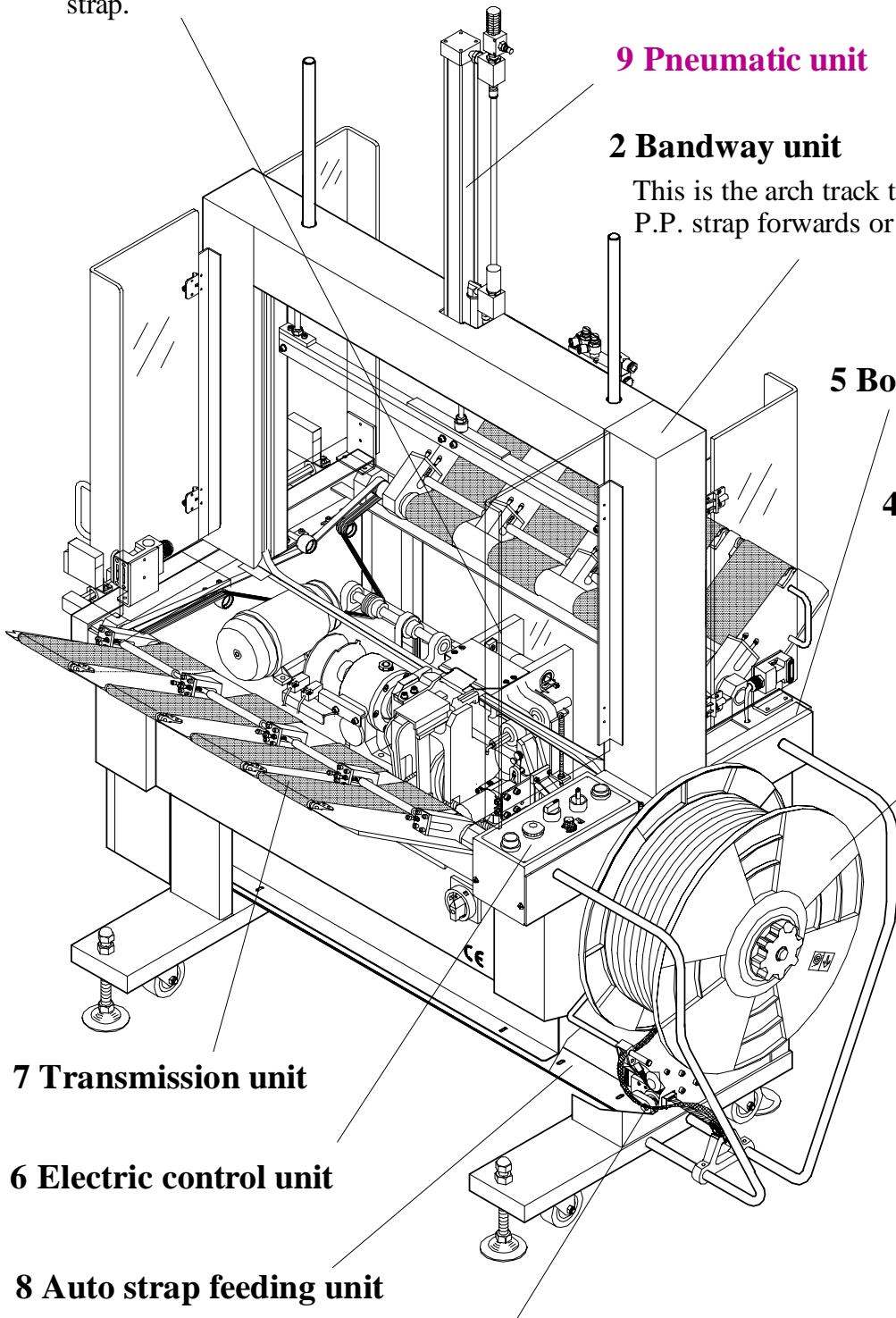



### 3. Technical Date

#### a. TP-601A

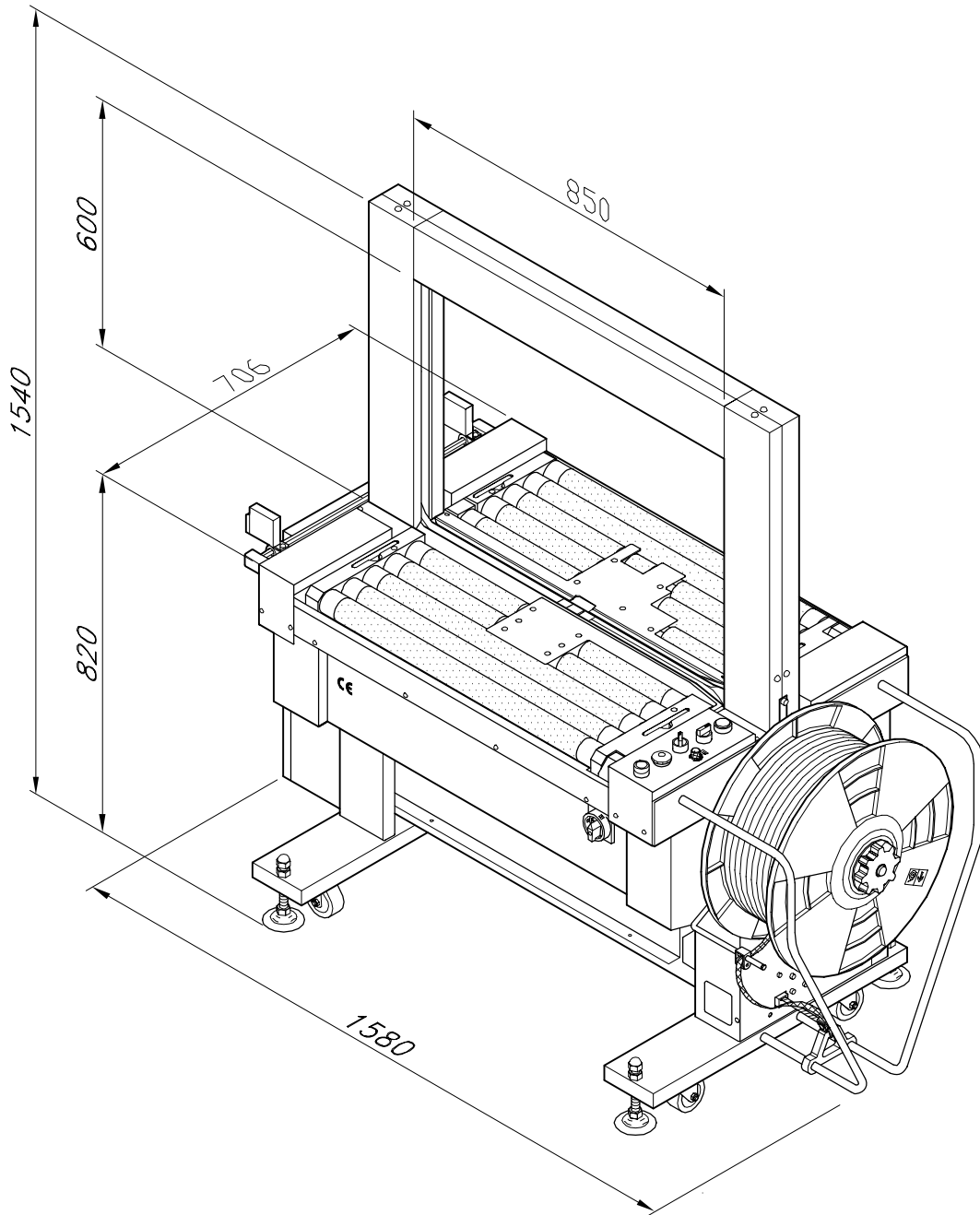

Sealing method	Heat
Strap width:	8 mm to 12 mm
Strap reel diameter:	200 mm (280mm OPTION)
Width :	1580 mm
Depth:	706 mm
Table height:	820 mm
Electrical connection:	AC 220V/380V/400V/415V, 3PH
Weight:	330 kg

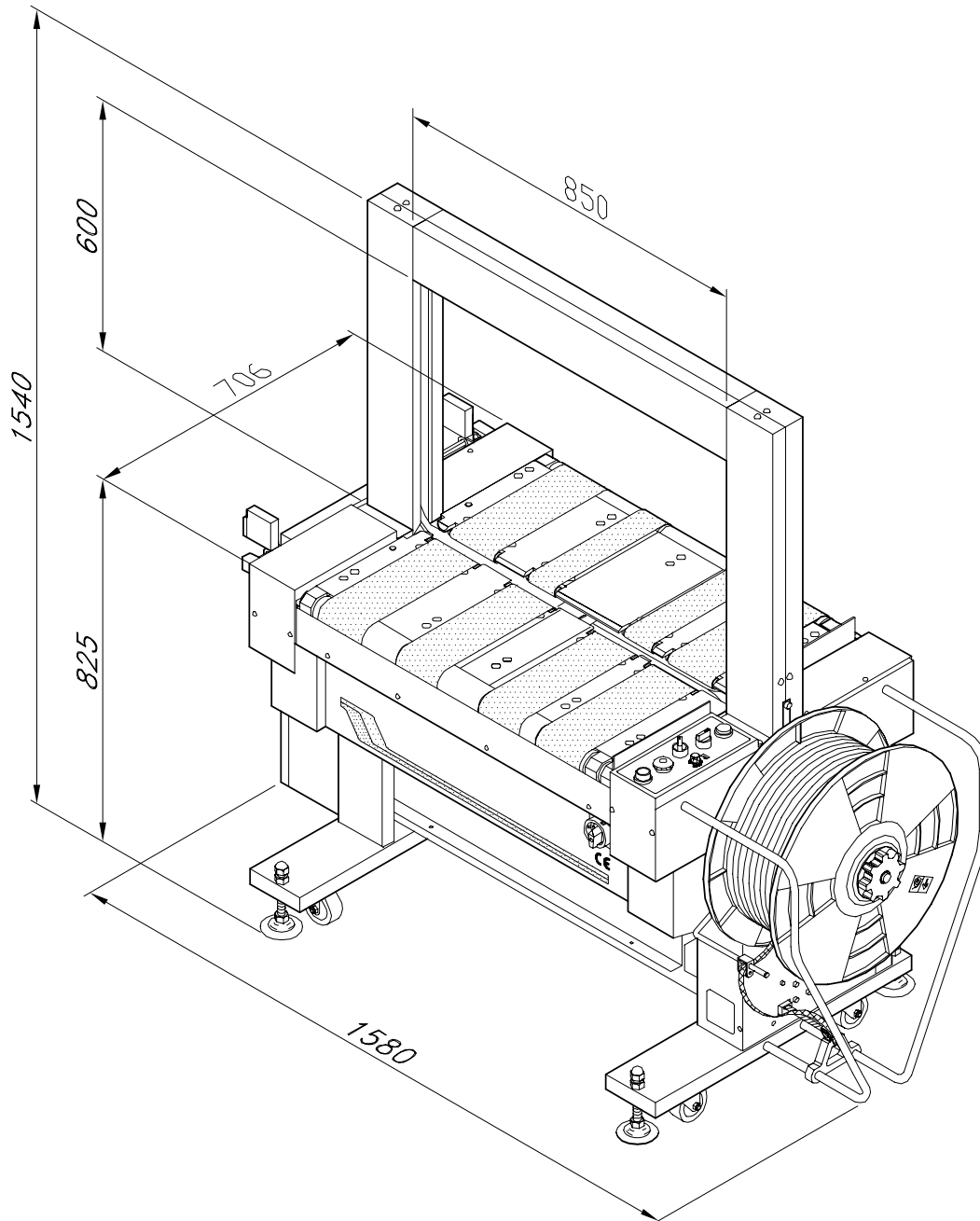
**b. TP-601B**

Sealing method	Heat
Strap width:	8 mm to 12 mm
Strap reel diameter:	200 mm (280mm OPTION)
Width :	1580 mm
Depth:	706 mm
Table height:	825 mm
Electrical connection:	AC 220V/380V/400V/415V, 3PH
Weight:	330 kg

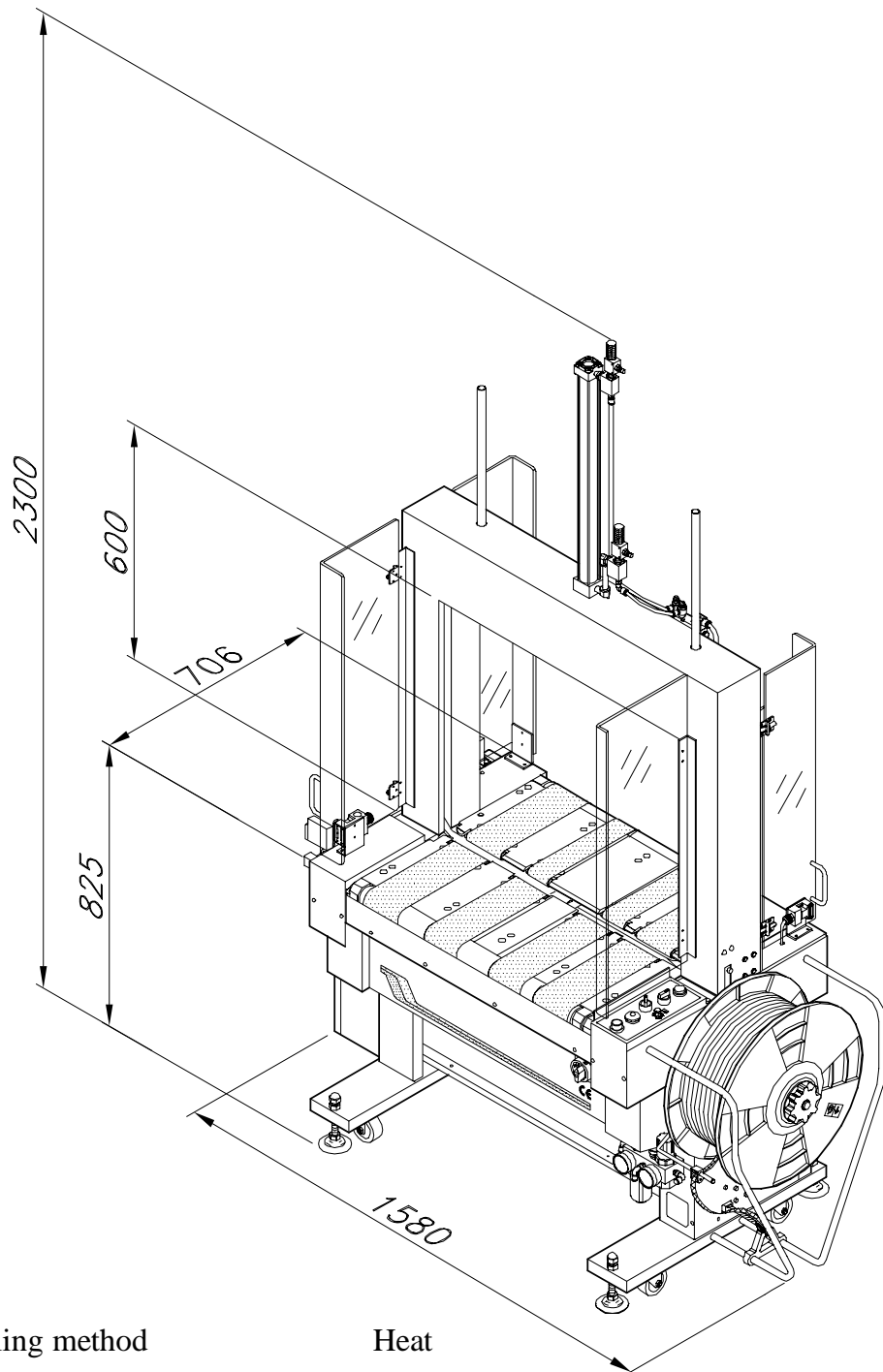
**c. TP-601BP**

Sealing method	Heat
Strap width:	8 mm to 12 mm
Strap reel diameter:	200 mm (280mm OPTION)
Width :	1580 mm
Depth:	706 mm
Table height:	825 mm
Electrical connection:	AC 220V/380V/400V/415V, 3PH
Weight:	347 kg

## 4. Control Panel

### ① Start Switch

This is the switch to start a strapping operation. A strapping cycle is completed only after actuation of this switch.

### ② Stop Switch

Push the stop switch in case of emergency. Simply push this the strapping operation stop switch to completely stop.

\*Lock stop switch if strapping has to be interrupted for a short period of time. The machine will stop but the heater element will maintain its temperature. The machine will then be immediately ready for operation without need for warming-up of the heater element.

### ③ Reset Switch

This is the switch to activate auto strap feeding. In addition, it is used for troubleshooting. If the strap is mis-fed, you can push this button to solve the problem.

### ④ Auto/Hand/Transit Selector Switch

With the selector switch placed to HAND position, the table conveyors will stop running and the photo eyes will not be activated but the machine can strap if the start switch is activated. With the selector switch is turned to AUTO position, the table conveyor will run and the photo eyes are activated so that the machine will automatically strap the package when it passes below the arch. If the selector switch is turned to "TRANSIT", the package will be advanced without being strapped. (The conveyor rollers/belt will run but the photo eyes will not activated.)

### ⑤ Strap Selector Switch

This switch is used to select how many (1,2, or N) straps are required for each package.

### ⑥ Tension Adjustment Knob

External adjustment of strap tension by step-by-step rotation of this knob.

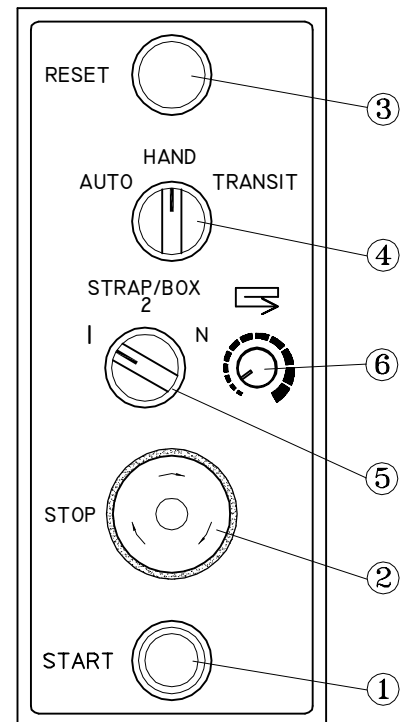

## 5. Electric Unit

**Timer, T1 (30):** T1 timer determines the time necessary for strap take-up. Set T1 timer bearing in mind the time required for strapping the minimum-size package. Normally, Timer T1 is set at about 0.5 seconds, but may have to be adjusted depending on arch size.

### Timer, T3 (31):

When you set the machine so that it applies three straps per box, this timer defines when the second strap is to be applied. By adjusting this timer, you can make the time interval between application of the first/second and second/third straps identical.

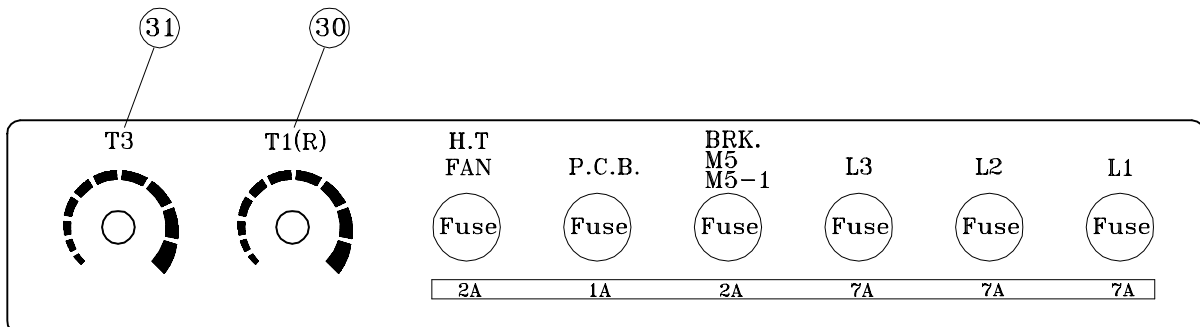

## 5. Electric Unit

(OPTION For SIEMENS PLC )

### ③③ Timer, T3 :

When you set the machine so that it applies three straps per box, this timer defines when the second strap is to be applied. By adjusting this timer, you can make the time interval between application of the first/second and second/third straps identical.

### ③④ Strap After Press Bar Time

This is the timer for machine to strap package after press bar descends.

### ③⑤ Transit Speed (OPTION)

External adjustment of transit speed by simple turn of a dial.

### ③⑥ Press Bar ON/OFF

Bundle press function only when PRESS BAR selector is set at " ON".  
Strapping without bundle press when PRESS BAR selector is set at " OFF".

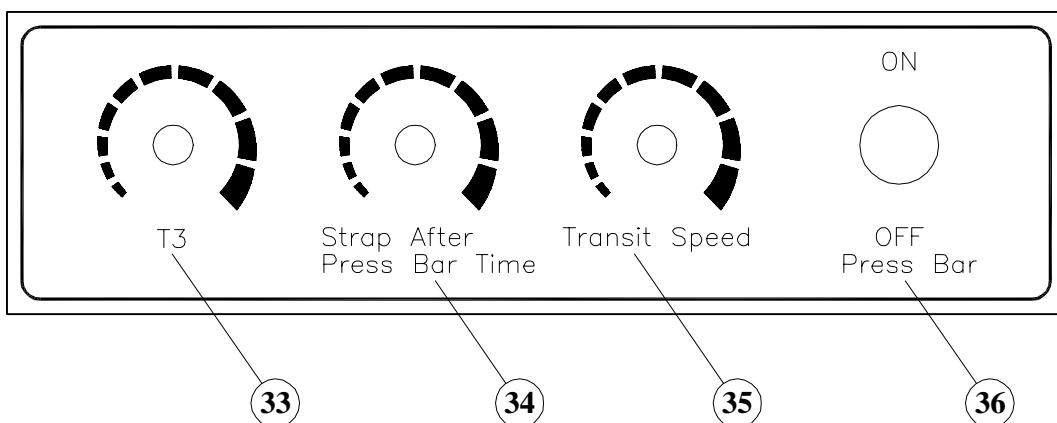

## 6. How to Load P.P. Strap

- **Ensure that the power switch is turned off before loading P.P. strap.**

### Step 1

Place a strap coil on the reel drum in according to the arrow direction as indicated on the Reel Out Circular (9). After placing it, put the Reel Out Circular on the strap coil and tighten it by the Reel Nut Handle (10).

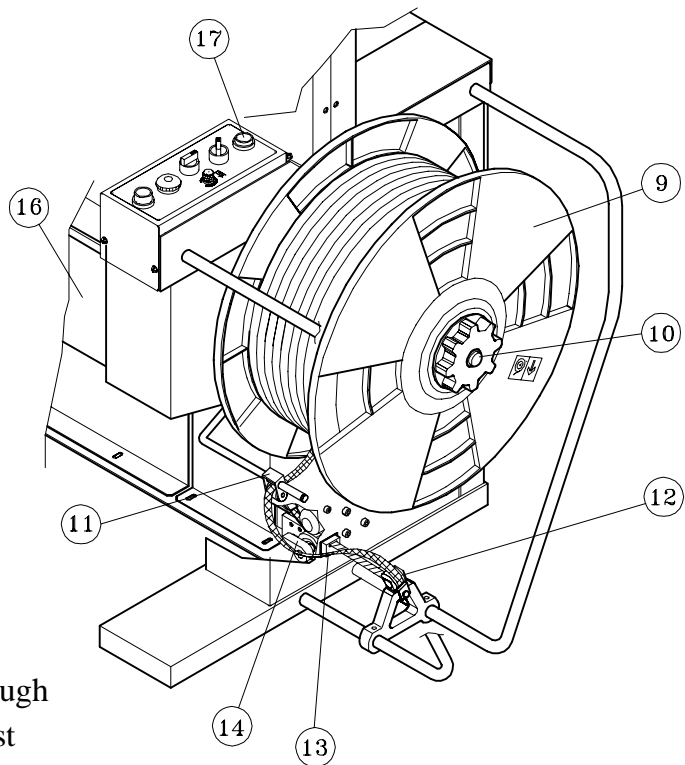

### Step 2

Thread the tip of P.P. strap into the Band Guide Roller (11). After that, push it through the Free Angle (12). At this moment, twist the strap so that the inside part of the P.P. strap turns out downward and outside surface touches on the roller. See the drawing.

### Step 3

Insert P.P. strap into the Pool Feed Shooter (13), pushing the lever (14) down and feed P.P. strap about 1-2 cm beyond Pool roller (15).

### Step 4

Turn on the power supply switch, and then push Reset Switch (17). After about 4 seconds, the strap will automatically go into the arch and pool.

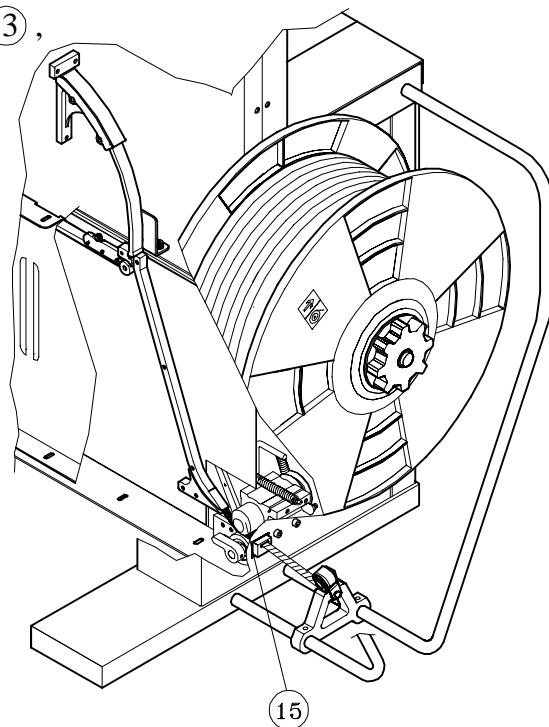

## 7. How to Operate

1. Turn on the switch (make a 90-degree clockwise turn). The front door will lock at the same time and the strap will be automatically fed into the accumulator box. If you want to open the front door, turn off the switch first (make a 90-degree counterclockwise turn).

The operator can now open the front door without risk. (See drawing below)

2. Wait for about 2 minutes until the heater element has reached its required operating temperature.
3. Switch to AUTO operation mode. Make the bundles line up in the middle of the conveyors. Let bundles pass the photo eyes of the machine and be strapped as the straps number setting one by one.
4. After operation, turn off the power supply switch.

## 8. Recommendations for Trouble-free Operation

1. Make sure to turn off the power supply switch, when maintenance and/or exchange of strap coil is required.
2. Pull the strap out of the Accumulator Box and rewind it on the Reel Unit to prevent cambering, if the machine will not be used for long periods of time.
3. In order to change the strap width, use the strap conversion kit which is sold as an option.
4. When the electric plug receptacle has to be changed, check the revolving direction of motor. (P12 NO. ⑮ ).
5. Always keep the machine clean, especially by removing dust and strap fluff in the vicinity of the sealing head and heater unit.
6. Do not use extension cords.

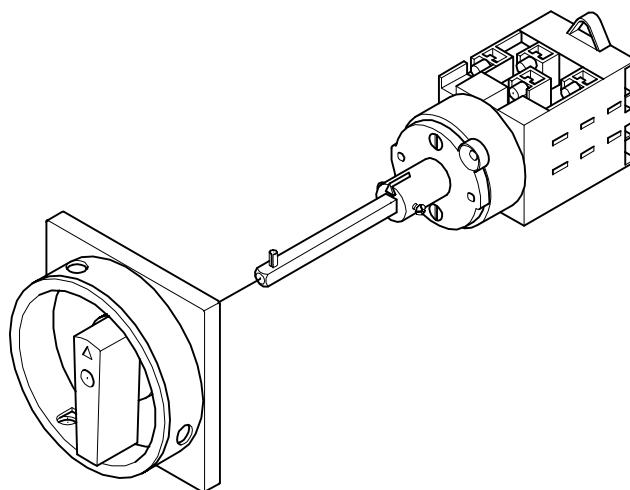



## 9. Adjustments

### (1) Heater temperature

Set the knob to position 4 or 5

Adjust the heater temperature by selecting a value between 1 and 6. Choose the suitable temperature, bearing in mind the environmental conditions of the machine. If the heater temperature is too high or too low, a proper seal will not be obtained. Gradually increase or reduce the heater-knob value until obtaining an optimum seal.

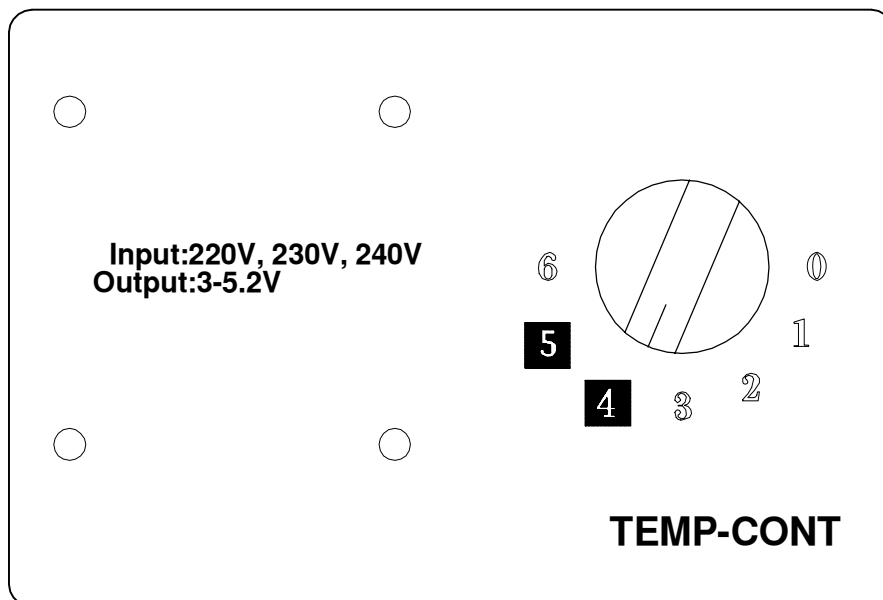

## (2) Feed and take-up mechanism

If this unit is not correctly adjusted, strap feed and take-up will become irregular.

Normally, this unit is set to accept P.P. strap with the thicknesses of 0.55mm-0.75mm  
 If a different strap thickness is used, adjust the section marked by a circle in the drawing so that the clearance between the Upper Roller Spring (23) and the Upper Shaft Spring Hook (24) should be the thickness of the strap you are using. Strap can only be taken up properly if this unit is precisely adjusted. (If not, strap will be sealed before being tightened around the package ) Moreover, strap will leave the chute arch track when feeding into it if there is no clearance.

1. Check if the control unit returns to its original position. Insert the strap between Feed Roller (22) and Upper Feed Roller (21) .
2. Loosen 2 Bolts (27) holding the right-hand Block Arm (25) with the Press Arm Shaft (26) . Press Arm Shaft can then easily be moved by hand.
3. Adjust so that there is a clearance between the Upper Roller Spring (23) and the Upper Shaft Spring Hook (24) the same as the thickness of the strap you are using.
4. Tighten 2 Bolts (27) .

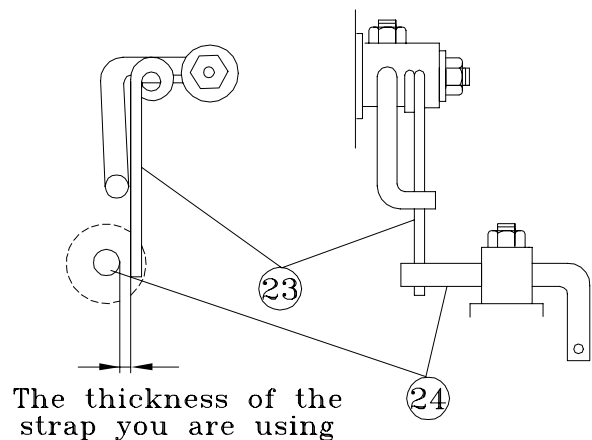
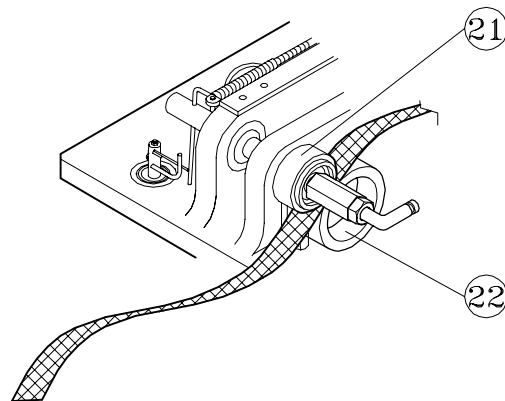
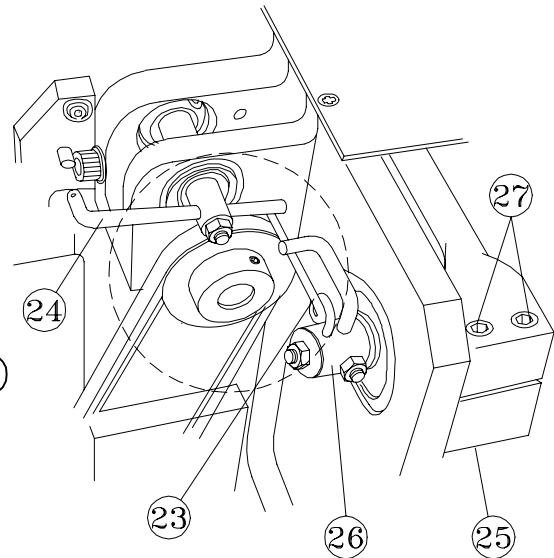

### (3) How to adjust LS3, LS2

Figure 1: LS-3 Home Position

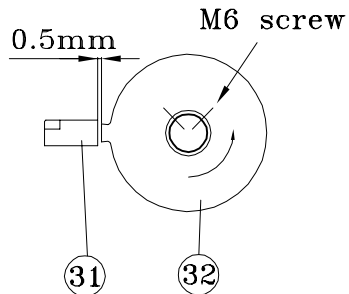

Figure 1-1

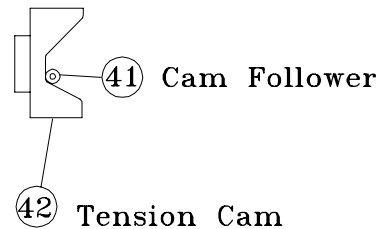

Figure 2: LS-2

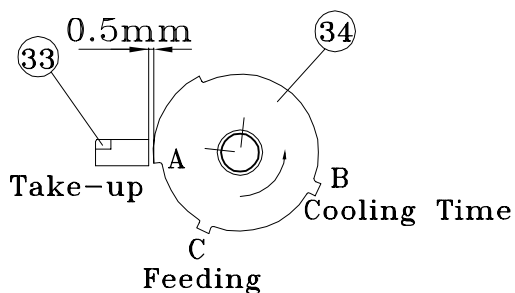
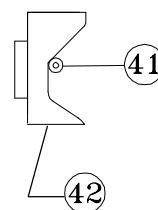

Figure 2-1



**Figure 1** shows the correct position for LS3 Proximity Sensor (31) and the Limit Switch Cam (32) while the machine is in home position.

The machine will stop as soon as the LS3 Proximity Sensor (31) detects that Limit Switch Cam (32) is activated. At this time, the Cam Follower (41) must stop at the corner position on the Tension Cam (42) as shown in **figure 1-1**. If not, please adjust according to the following instructions.

#### Adjustment

If Cam Follower (41) stops *before* the correct position:

1. Loosen the two M6 screws and turn the Cam Roller slightly clockwise, then tighten the M6 screws.
2. Reset the machine and allow it to cycle again to ensure that the Cam Follower (41) stops at the correct position.
3. If the problem has not been eliminated, please repeat the "Step One" until the Cam Follower (41) stops at the correct position.

If Cam Follower ④① stops beyond the correct position:

- a. Please also loosen the M6 screws but turn the Cam Roller slightly counterclockwise until the Cam Follower ④① stops at the correct position.

**Figure 2** shows the correct position for LS2 Proximity Sensor ③③ against the lobes of the Limit Switch Cam ③④ while machine is running.

When LS2 Proximity Sensor ③③ detects Lobe A of the activated running Limit Switch Cam ③④, the machine will stop about 0.3 seconds so that the machine can switch to take-up. In the meantime, Cam Follower ④① has to stay on the corner position of the Tension Cam ④② as shown in figure 2-1. If the Cam Follower is not at the correct position, please make the same adjustment as for LS3.

#### (4) Amount of strap in Accumulator Box

The machine has already been set in its Accumulator Box.

However, some adjustment may be required, depending on the actual quality or thickness of the strap used. If adjustment is necessary, proceed as shown in the following drawing.

- a. In case that there is an insufficient amount of strap in the Accumulator Box, loosen the Nut (27) and turn the Screw Bolt (28) counterclockwise.
- b. In case that there is an excessive amount of strap in the Accumulator Box, loosen the Nut (27) and turn the Screw Bolt (28) clockwise.

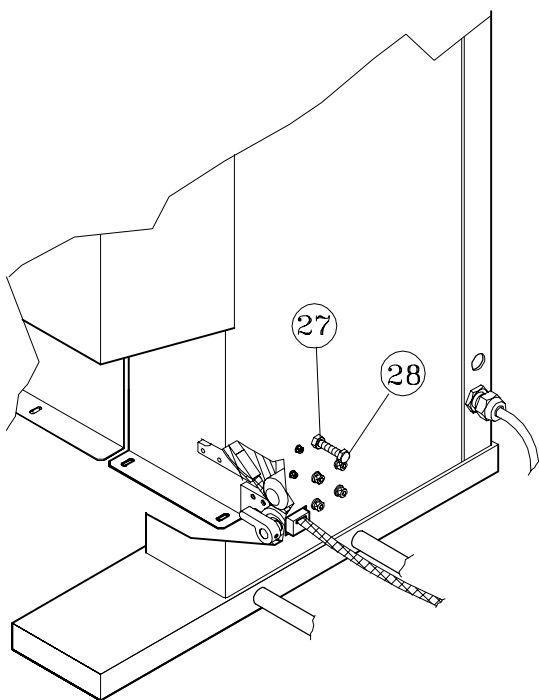

# 10. Installation of Arch Unit

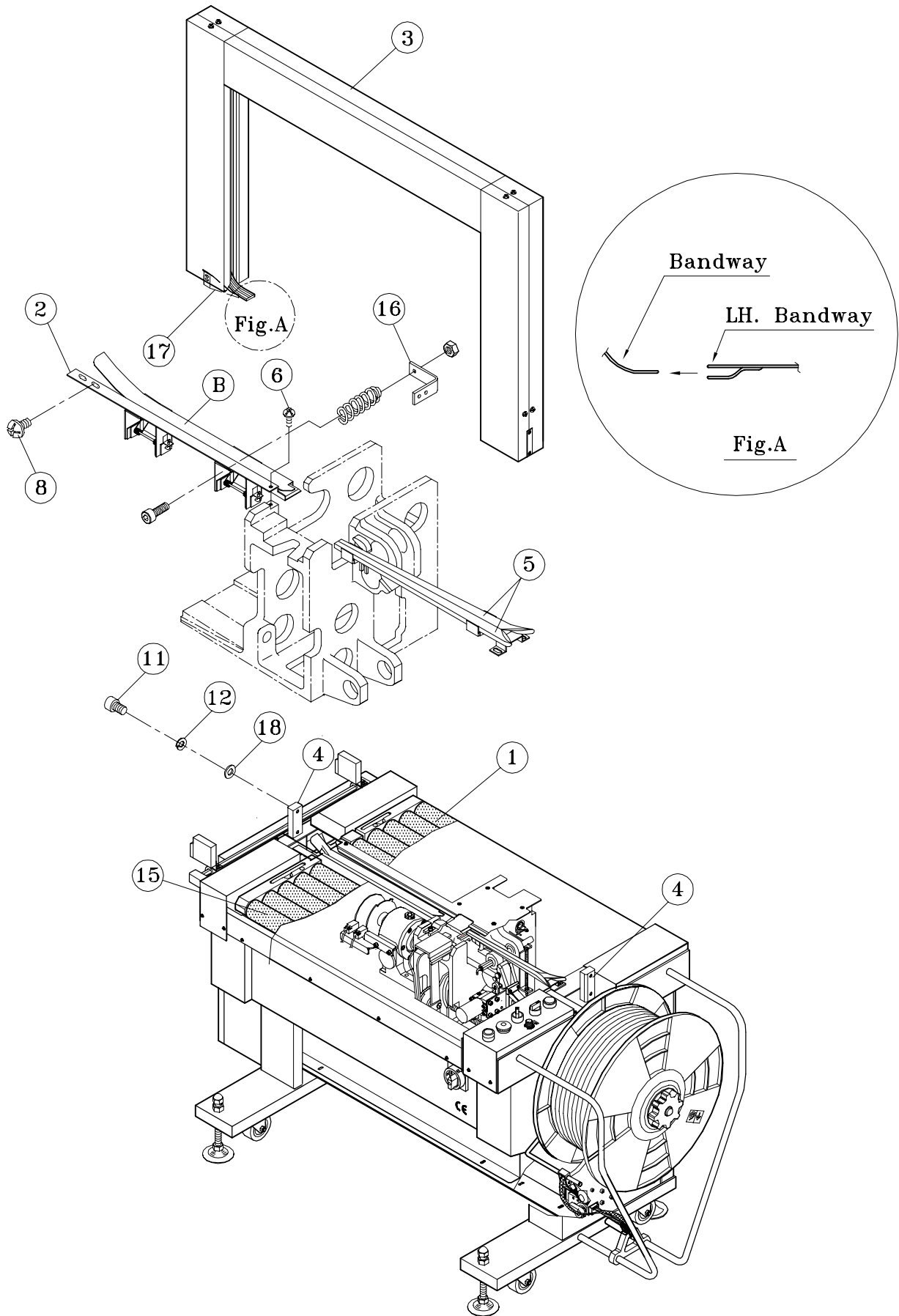

## 10. Installation of Arch Unit

(1) Open the Roller table ①, ⑮.

(2) Take the LH bandway ② off.

⑥ TMS, M5x8            1PC

⑪ HBS, M8x15        4PC

⑱ PW, M8 (A)        4PC

⑧ TMS, M6x8        2PC

⑫ SW, M8            4PC

(3) Slide the the arch unit ③ into the fixing brackets ④ and fix both sides of the arch frame with ⑪ ⑫ ⑱.

\* Please note that is imperative to open the flaps of RH bandway ⑤ to protect them when installing the arch unit in. (open the flaps, before inserting the arch unit in)

(4) Set the LH bandway ②, with ⑥ and ⑧.

a. Please note that the arch bandway (refer Fig. A) should be positioned between LH bandway and its fixing bracket.

b. Please set the LH bandway ② closely to ⑰ corner guide (PART NO. T6-2-21260).

c. Push the ⑰ Band guide Spring Bracket backward to check if B will be automatically turned open. If so, the installation is OK.

(5) Position the upper table ① ⑮ onto the machine body.

# 11. Wiring Diagram

## a. For TP-601A, TP-601B

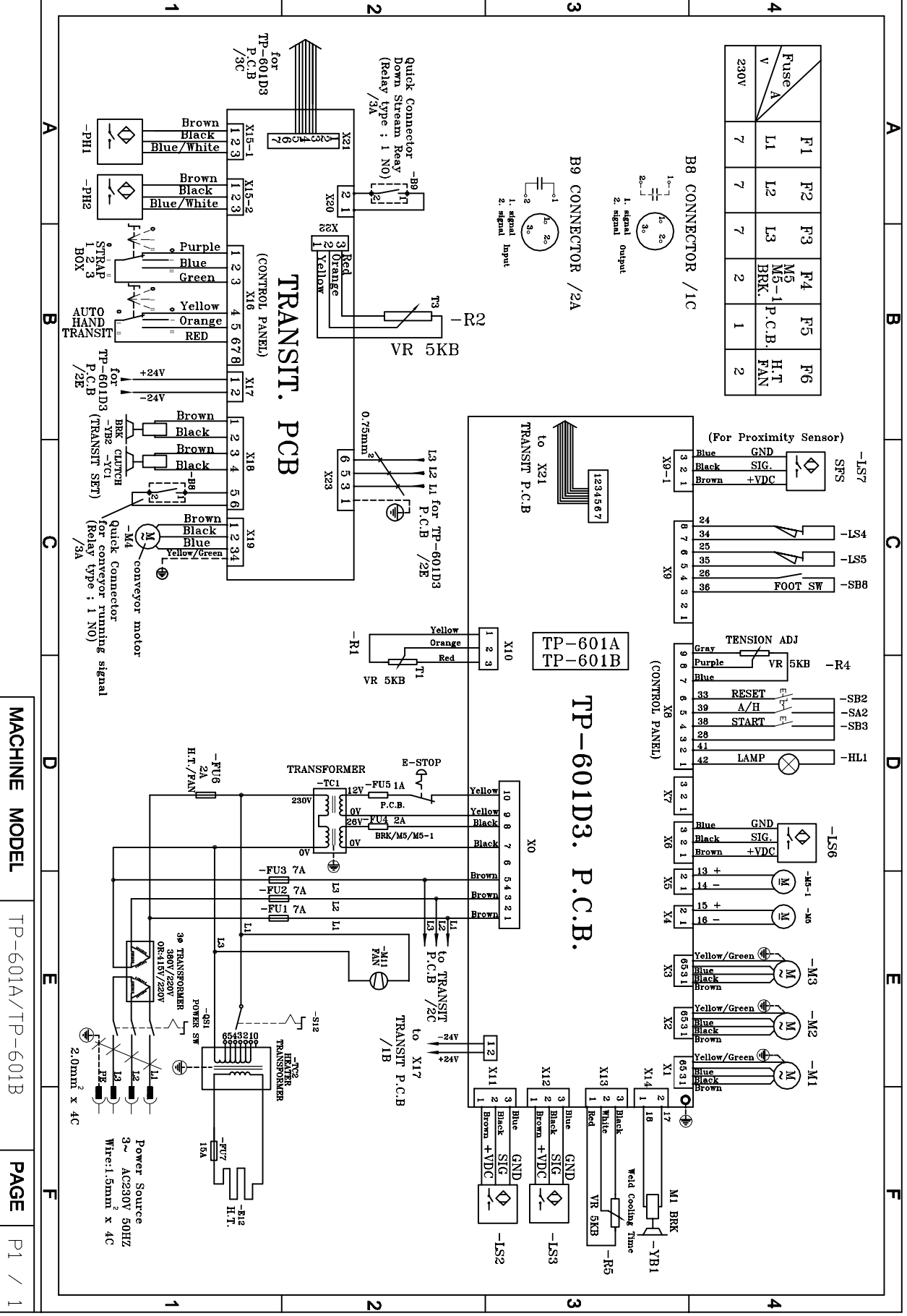



# 11. Wiring Diagram

## a. For TP-601A, TP-601B (For CSA)

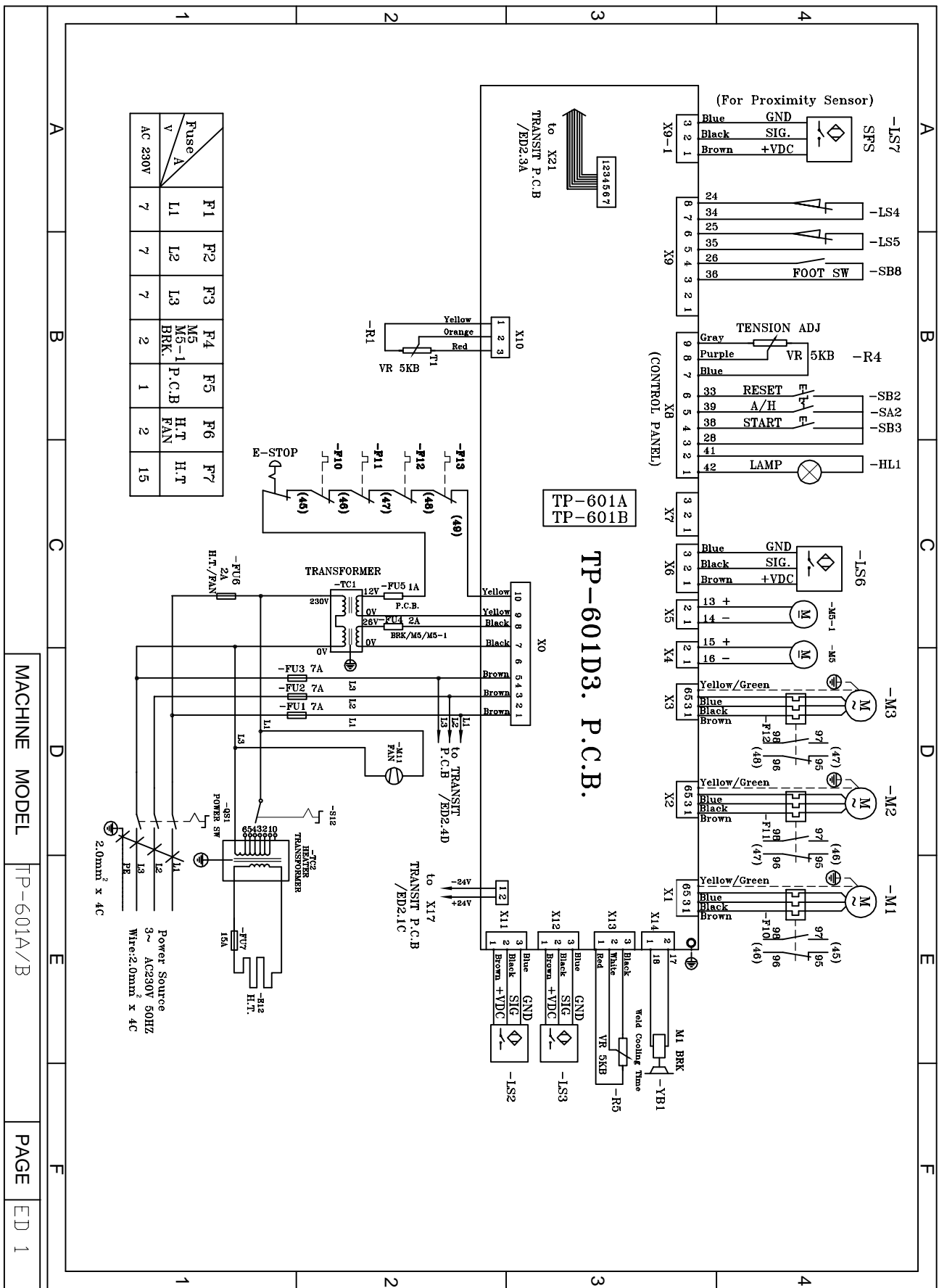

MACHINE MODEL TP-601A/B PAGE ED 1

# 11. Wiring Diagram

## a. For TP-601A, TP-601B (For CSA)

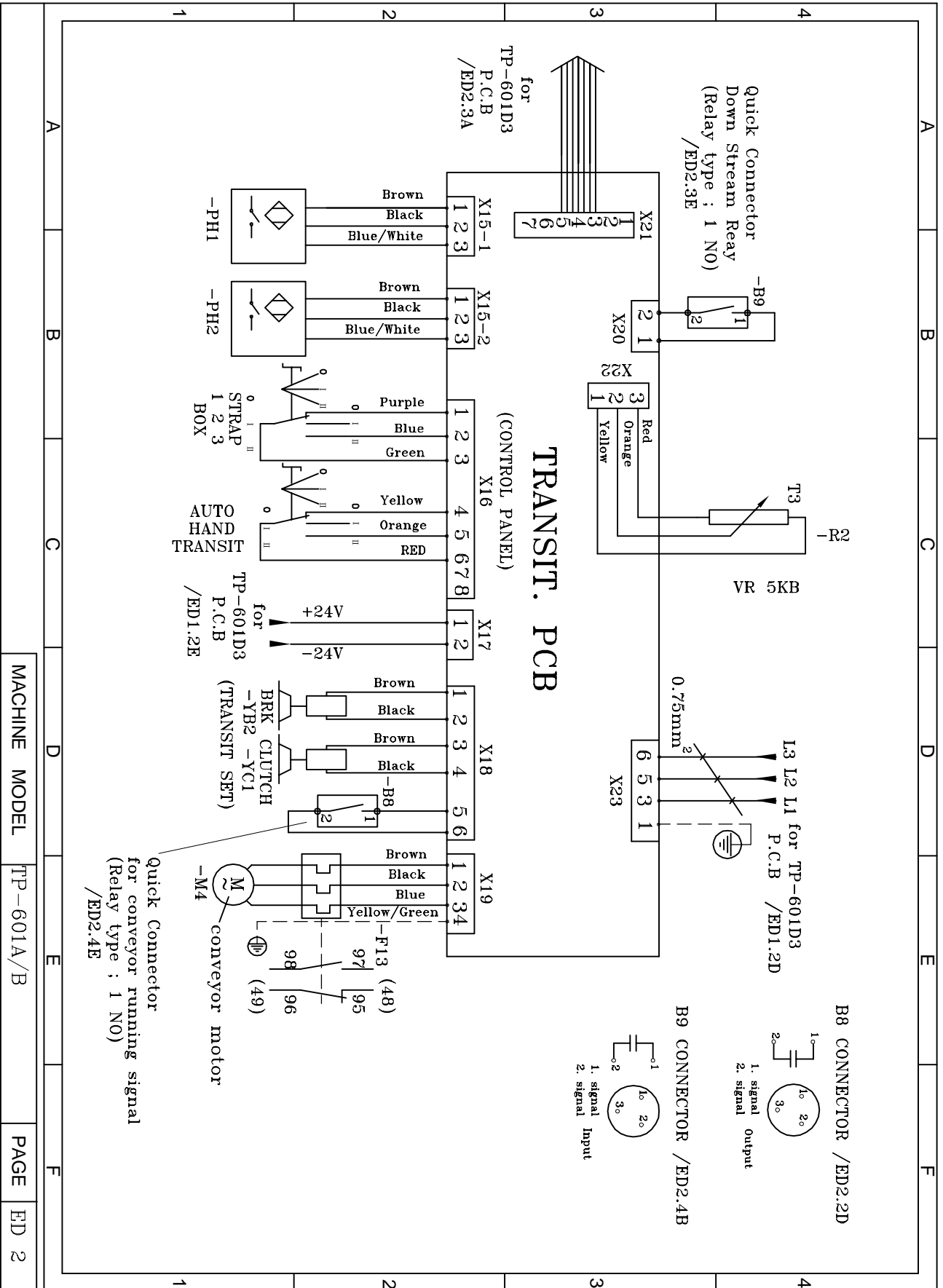

# 11. Wiring Diagram

## a. For TP-601A, TP-601B

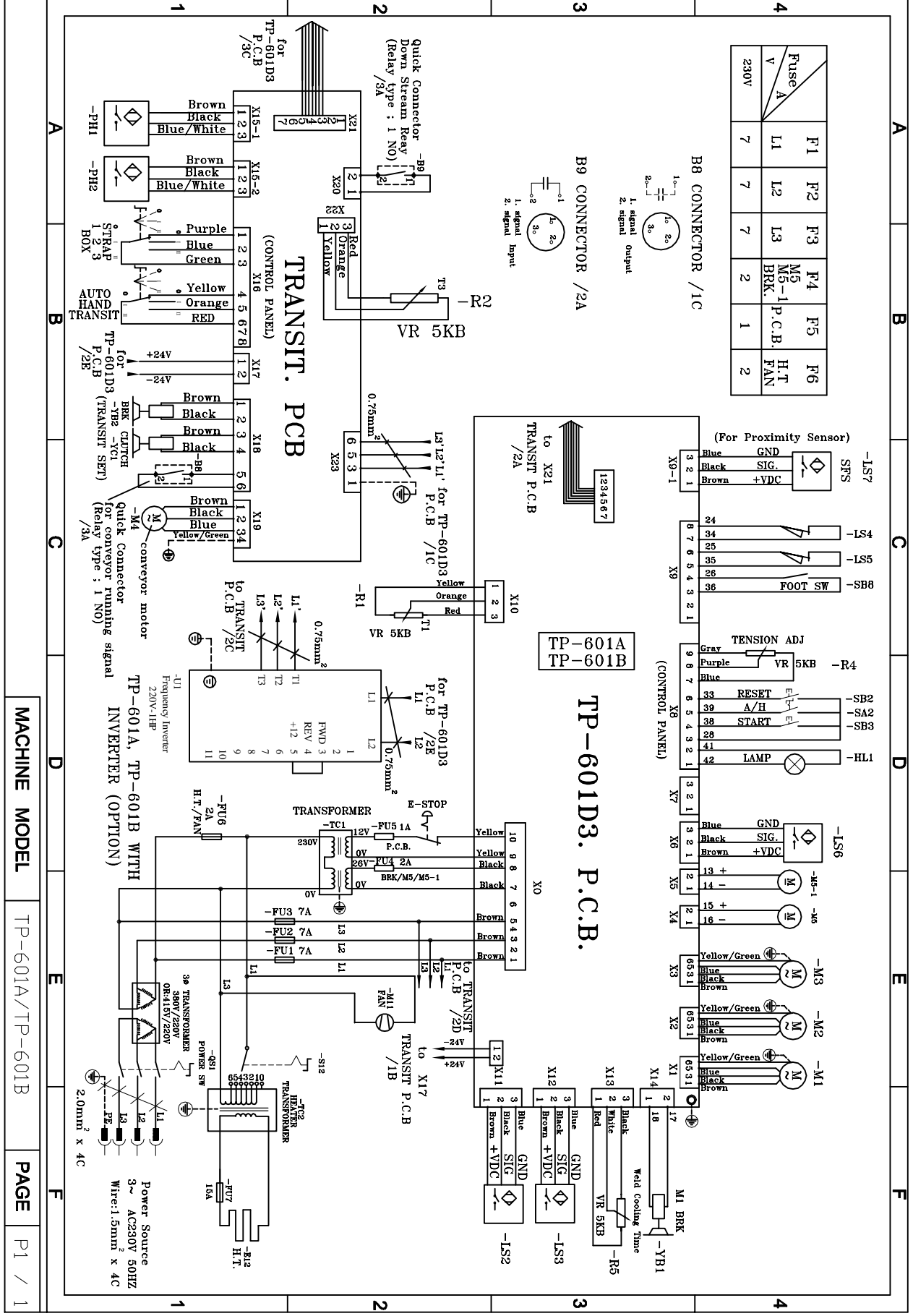

# 11. Wiring Diagram

## b. For TP-601BP

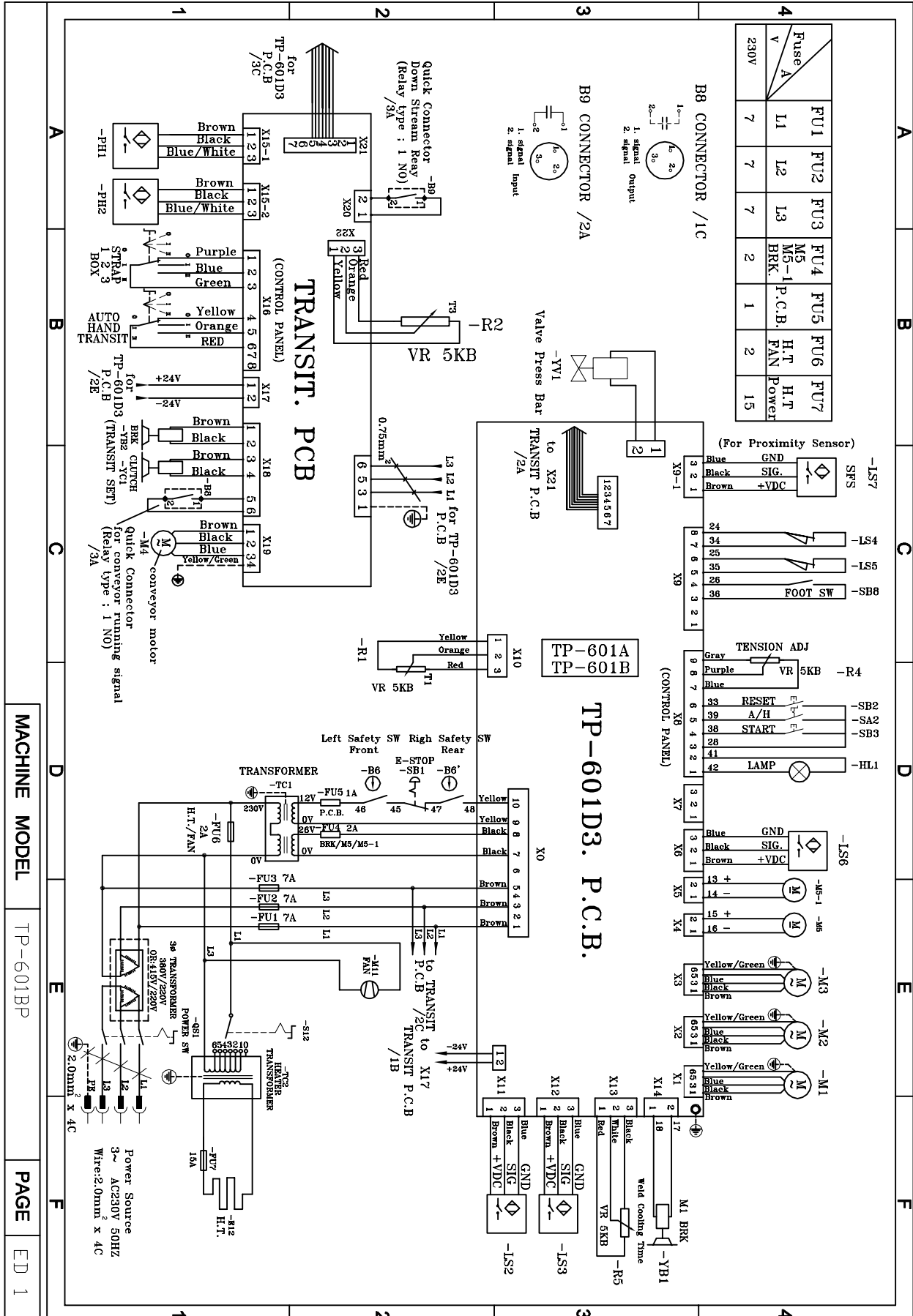

# 11. Wiring Diagram (OPTION For SIEMENS PLC)

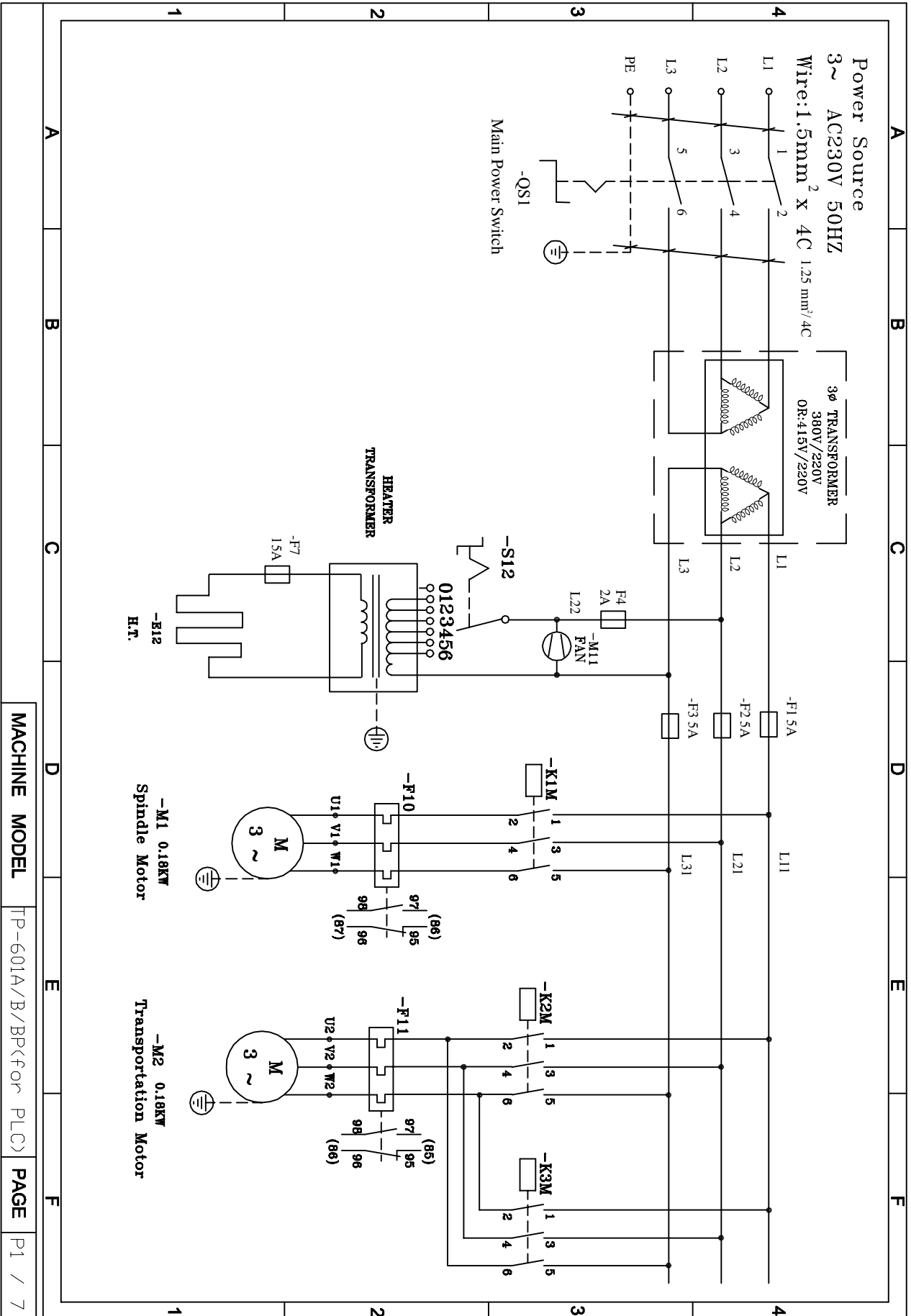

MACHINE MODEL

TP-601A/B/BP(for PLC)

PAGE

P1 / 7

# 11. Wiring Diagram (OPTION For SIEMENS PLC)

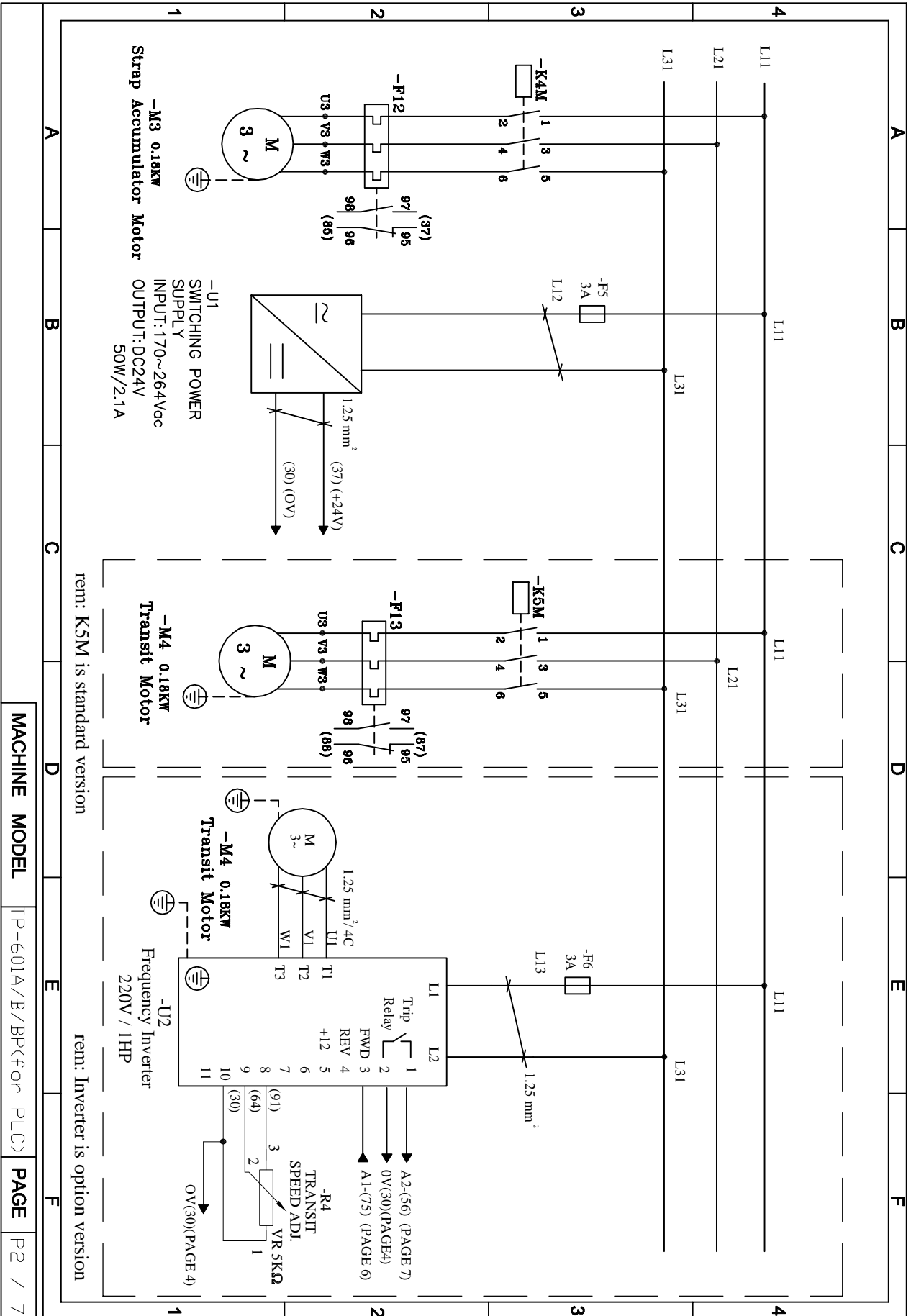

# 11. Wiring Diagram (OPTION For SIEMENS PLC)

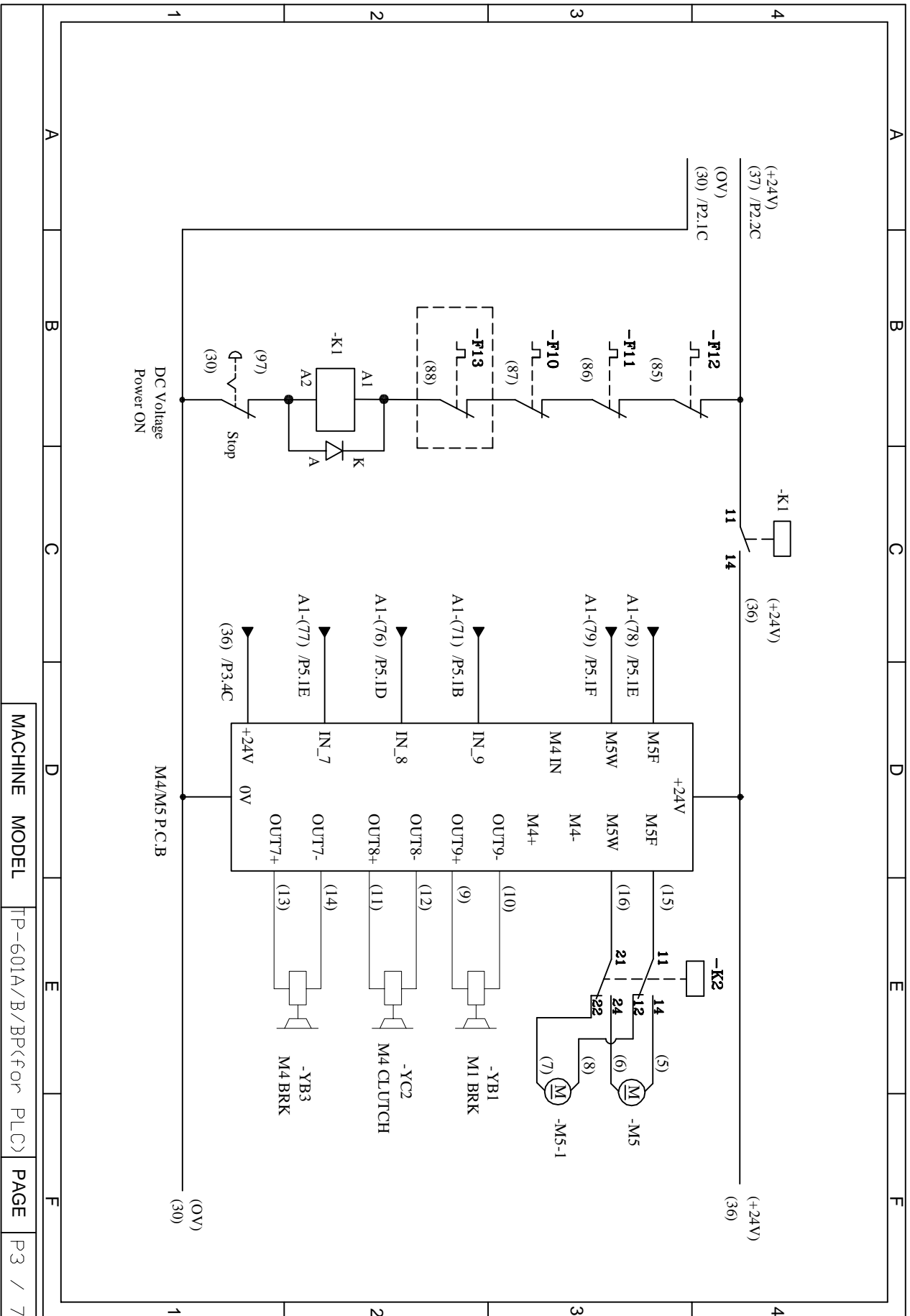

MACHINE MODEL TP-601A/B/BP(for PLC) PAGE P3 / 7

# 11. Wiring Diagram (OPTION For SIEMENS PLC)

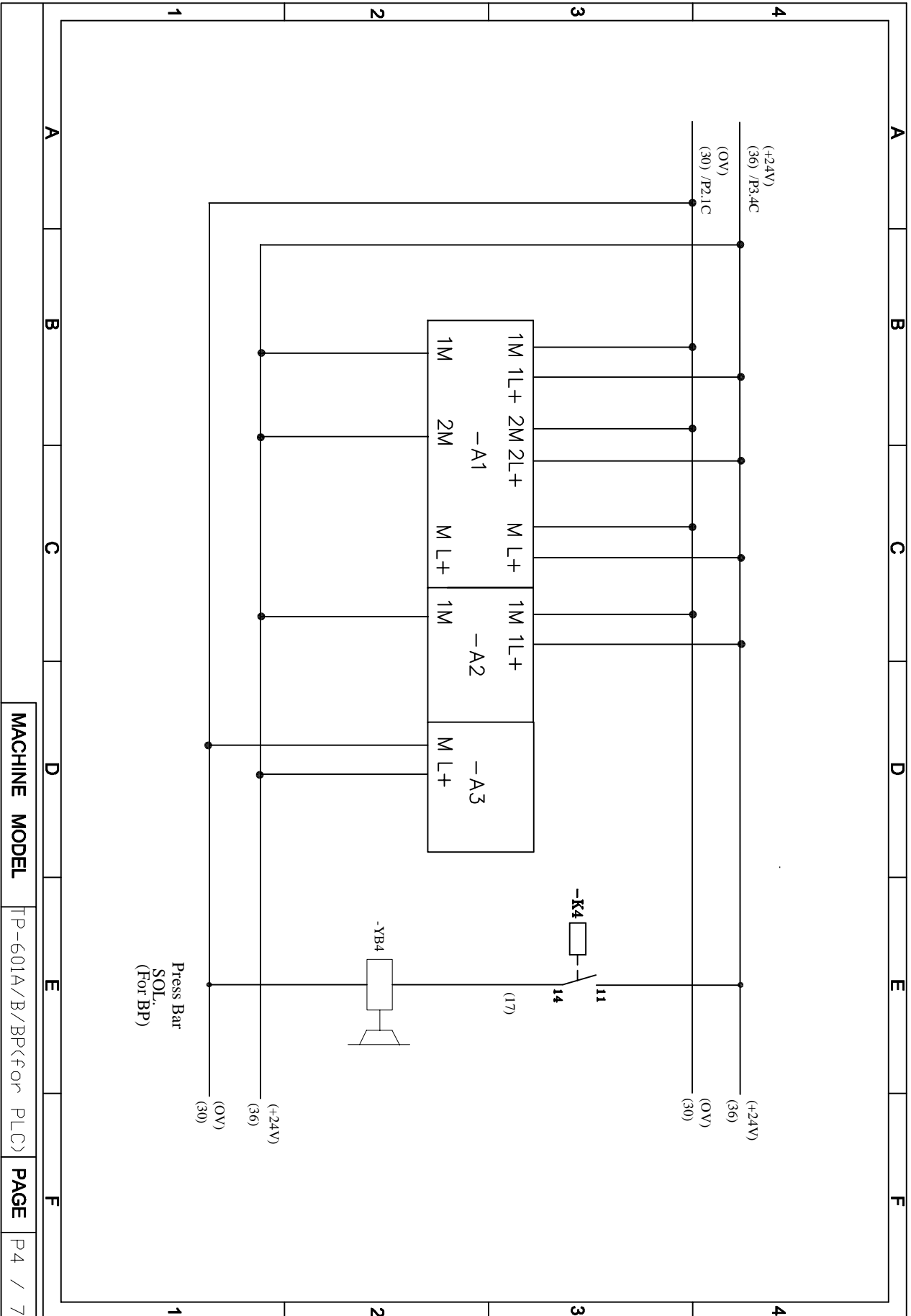

MACHINE MODEL

TP-601A/B/BP(For PLC)

PAGE

P4 / 7



# 11. Wiring Diagram (OPTION For SIEMENS PLC)

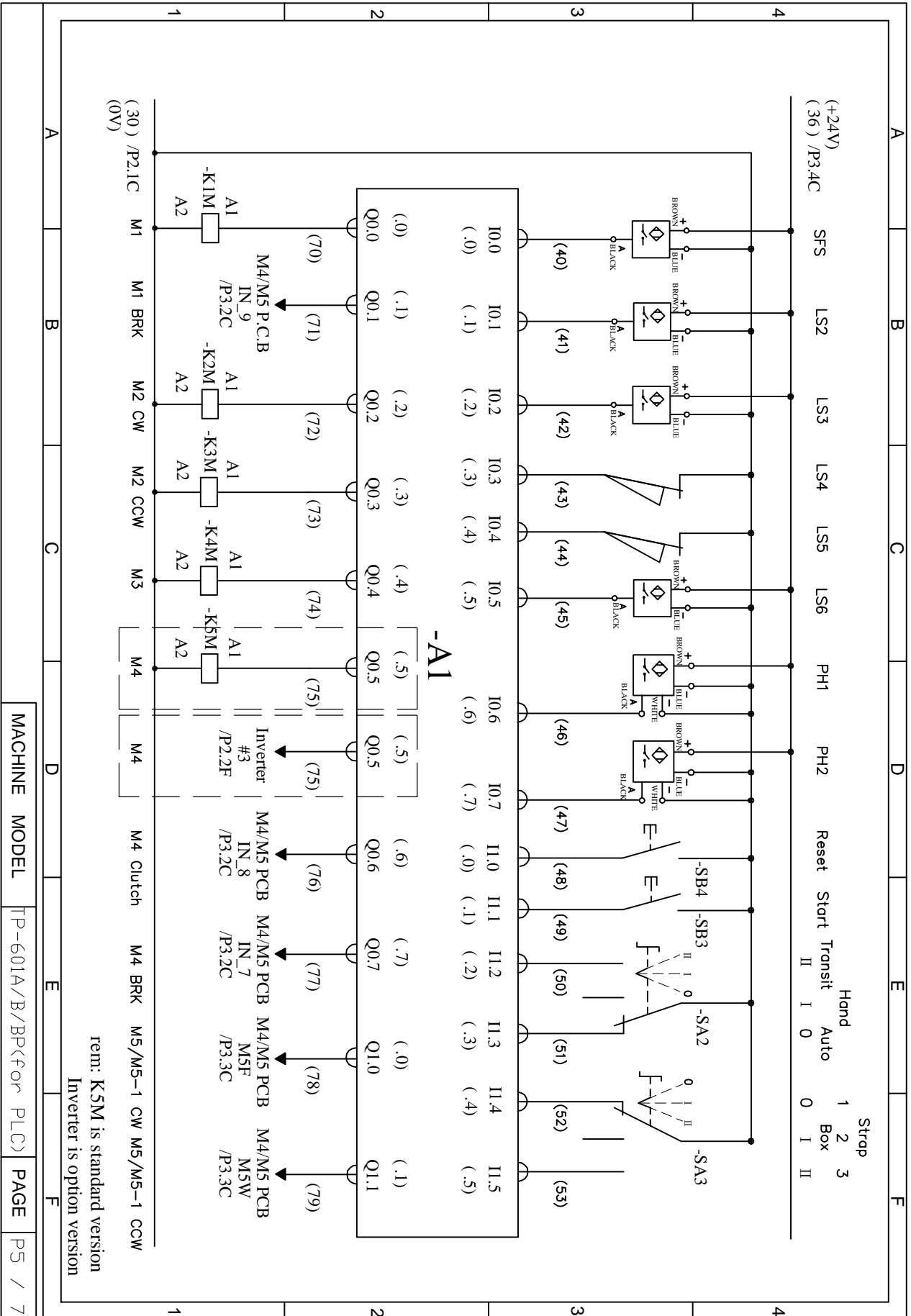

# 11. Wiring Diagram (OPTION For SIEMENS PLC)

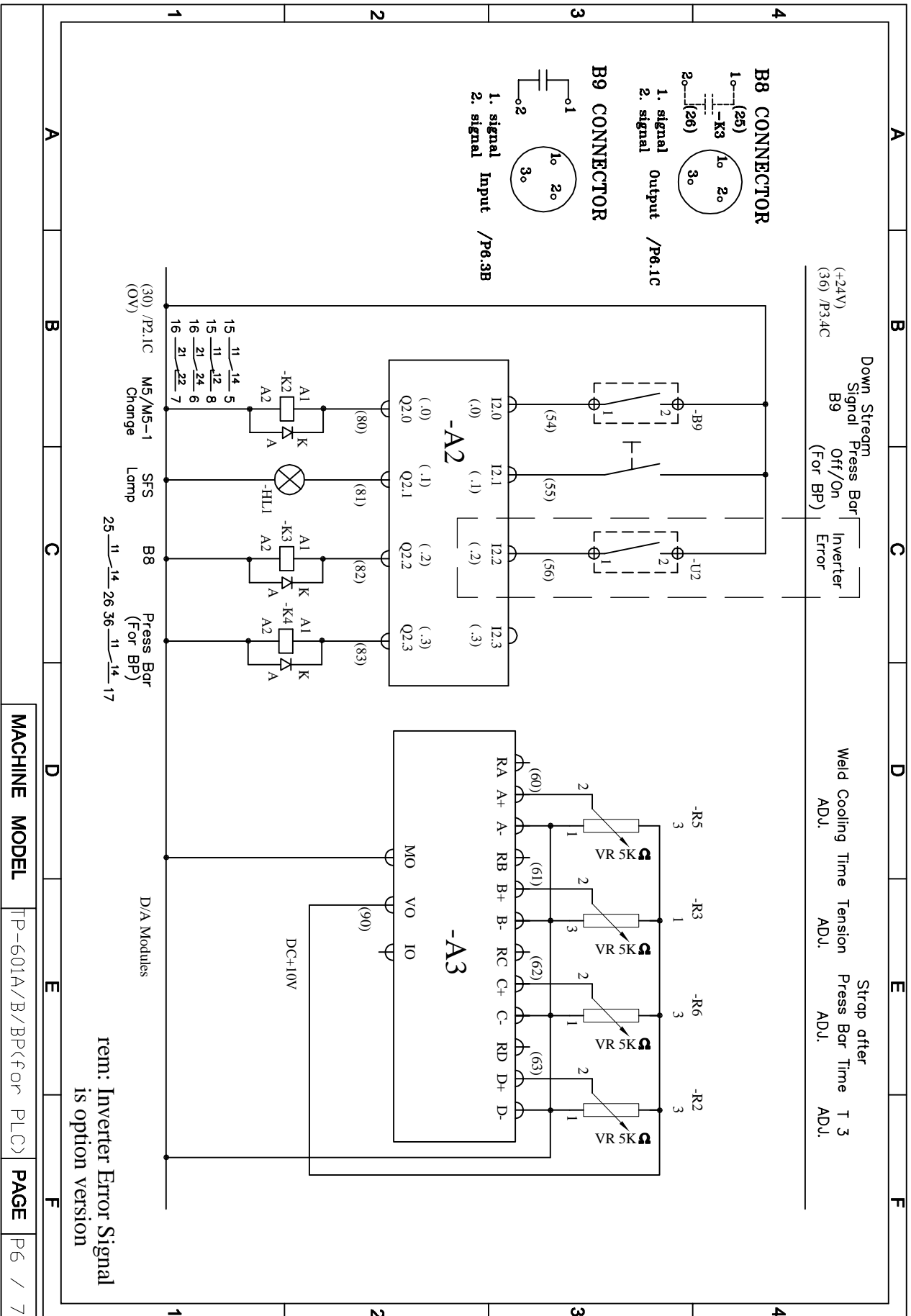

# 11. Wiring Diagram (OPTION For SIEMENS PLC)

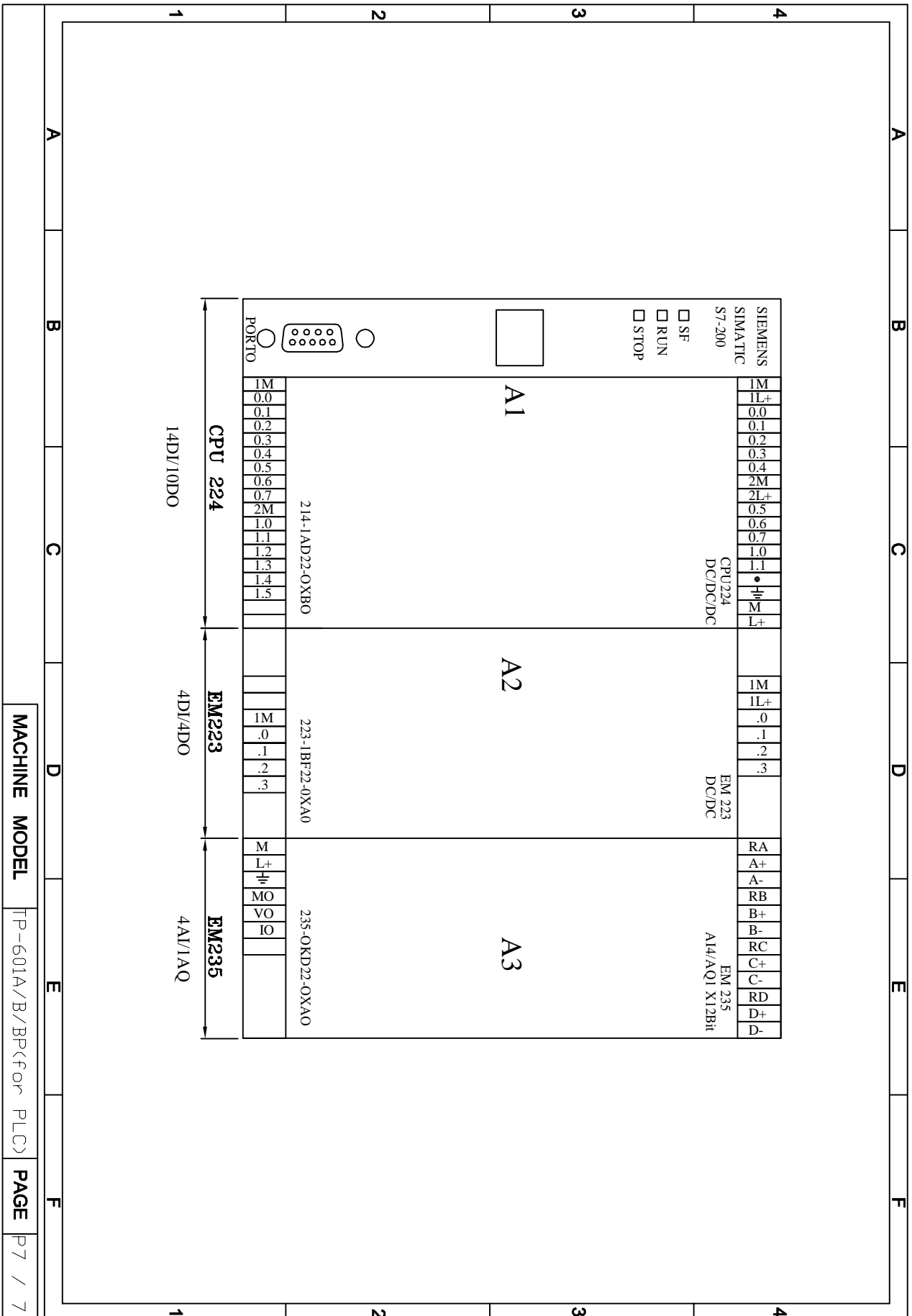

MACHINE MODEL

TP-601A/B/BP(for PLC)

PAGE

P7 / 7

## 12. Inverter Parameters Setup

(OPTION For SIEMENS PLC)

F0	×	F10	1	F20	×
F1	×	F11	0	F21	×
F2	×	F12	×	F22	×
F3	×	F13	×	F23	0
F4	×	F14	×	F24	2
F5	×	F15	×	F25	×
F6	70	F16	×	F26	×
F7	30	F17	×	F27	×
F8	×	F18	50	F28	0
F9	×	F19	×	F29	×

### 13. Troubleshooting

Problems	Probable Causes	Remedy
Machine works	(1) Incorrect strap threading direction on reel holder (2) Incorrect loading of strap (3) Strap gets in between strap coil and Reel Flange (4) Insufficient or excessive strap (5) Dust and strap residues in Feed Unit (6) Strap end is split (7) Loose strap at Reel Unit (8) Strap jumps out of arch track (9) Poor quality of strap (10) Improper positioning of package on Table Top	(1) Reload strap correctly (see P9) (2) Check if strap is twisted in loading section (see P9) (3) Reload strap (4) Adjust amount of strap accumulated (see P15) (5) Check and clean unit (6) Adjust Cutter Tension Spring or change cutter (7) Adjust or change Brake Tension Arm Spring (8) Adjust F/R mechanism (see P12) (9) Cut off the damaged part of strap or change the roll (10) Replace the package in the center of the Sealing Head
	(11) Wire inside or outside of Heater is broken, loose or out of connect (12) Improper setting of temperature (13) Value set at Tension knob is too high	(11) Check wire or change Heater (12) Adjust Heater Temperature (see P11) (13) Adjust Tension Knob (see P11) or increase weld cooling time
	(14) Tension Jaw Spring is worn-out or dislodged (15) Value set for Timer T1 is too short	(14) Change or reset Tension Jaw Spring (15) Adjust Timer T1 (see P7)

# 14. Pneumatic System Diagram

For Press Bar

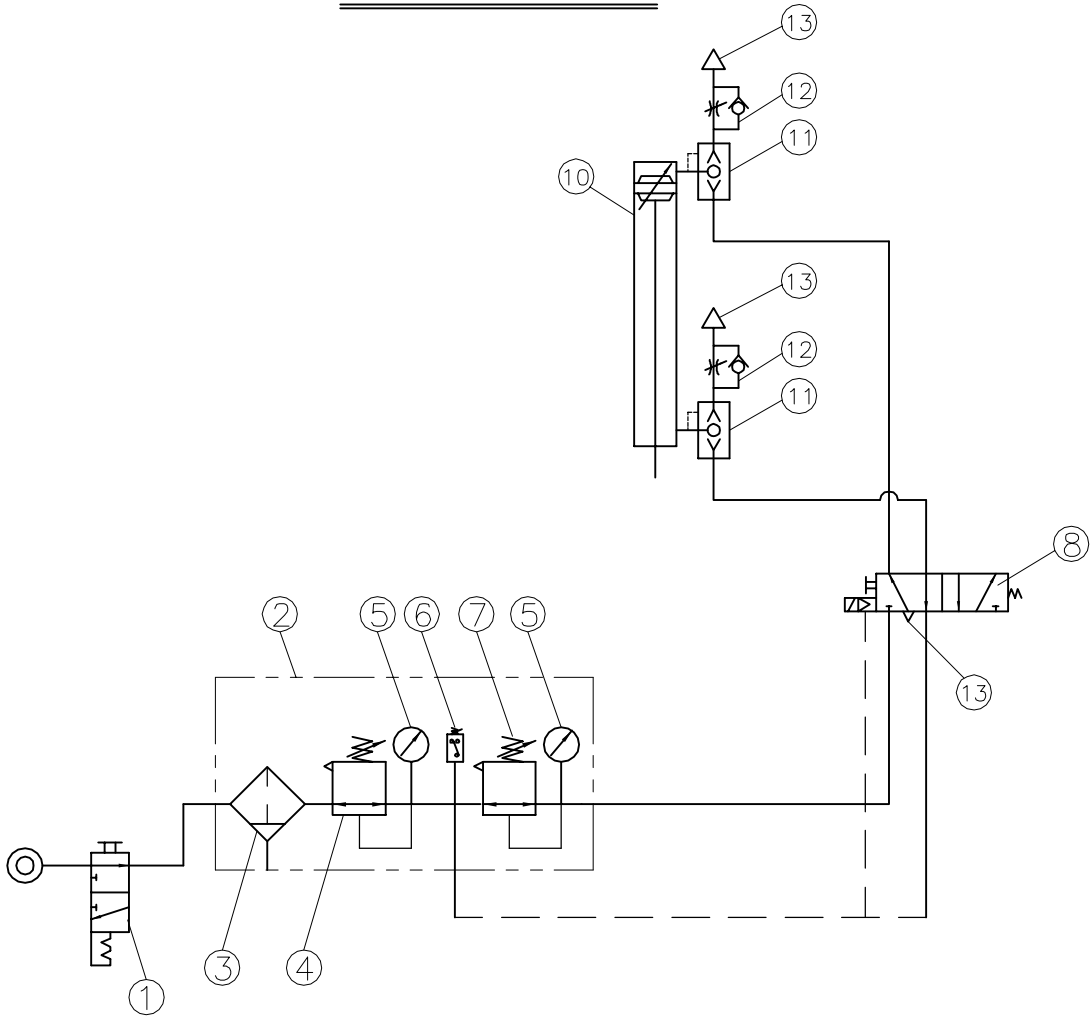

REF. NO.	DESCRIPTION	Q'TY
1	Slide Valve	1
2	Filter/Regulator Combination	1
3	Filter	1
4	Regulator (Hi-Pressure)	1
5	Pressure Guage	2
6	Pressure Switch (SQ11)	1
7	Regulator (Low-Pressure)	1
8	Solenoid Valve (Special)	1
10	Cylinder	1
11	Quick Exhaust Valve	1
12	Control Valve	1
13	Resin Silencer (3/8")	3

## 15. Installation of Cylinder Unit

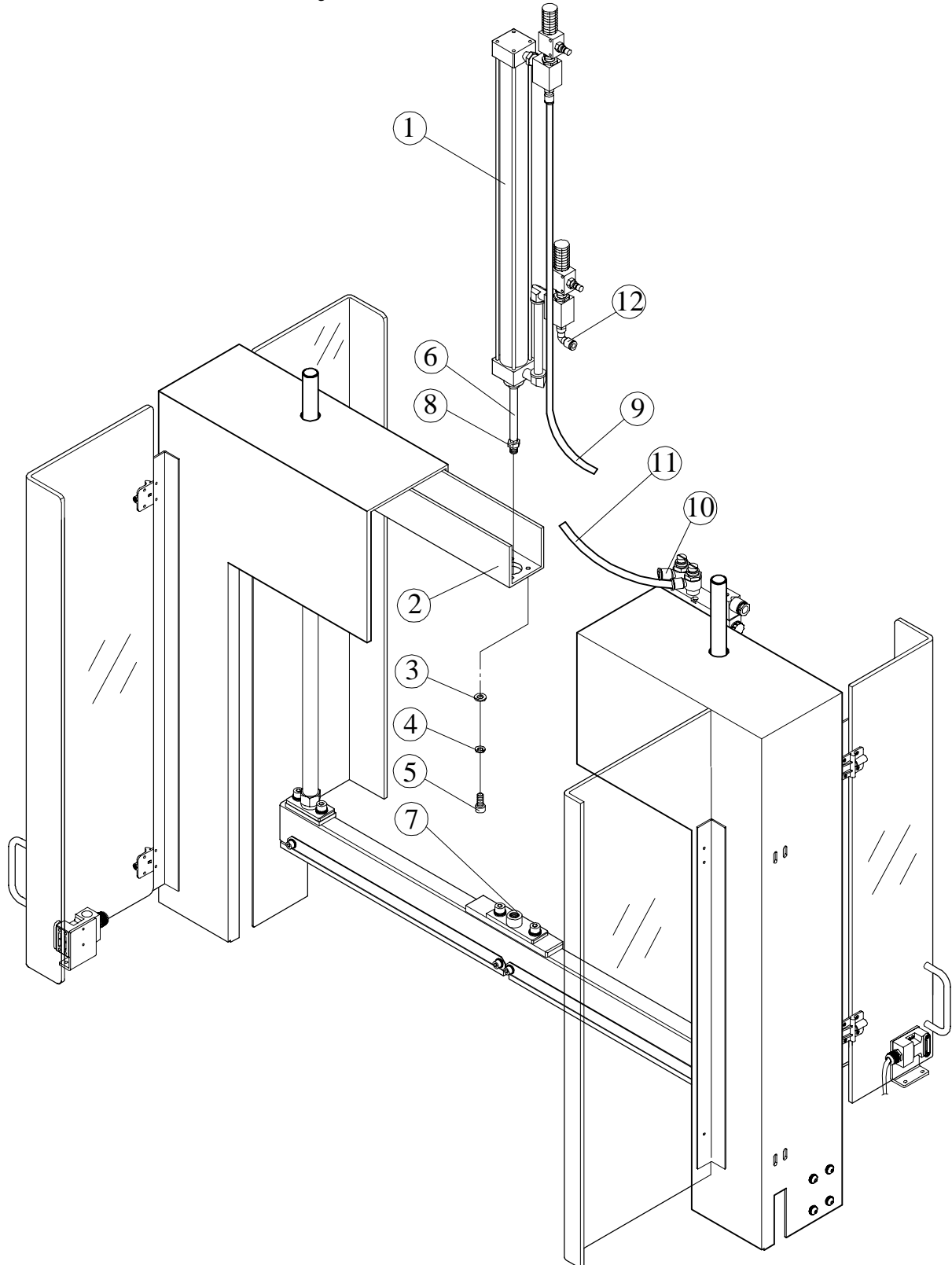

1. Stand the cylinder unit ① and through the shaft ⑧ into bracket ②.
2. Fix the cylinder unit ① on bracket ② by ③, ④, ⑤.
3. Screw the shaft ⑥ all into press bar ⑦ then tighten ⑧ down.
4. Insert the PU Tubing ⑨ into Tube Fitting ⑩.
4. Insert the PU Tubing ⑪ into Tube Fitting ⑫.

## 16. How to connect Upstream and Downstream Machine

### (1) B8 Connector (for Upstream machine):

Pin 1 and Pin 2: To send signal to upstream machine for entering the package (Refer to 11. wiring Diagram of PART I).







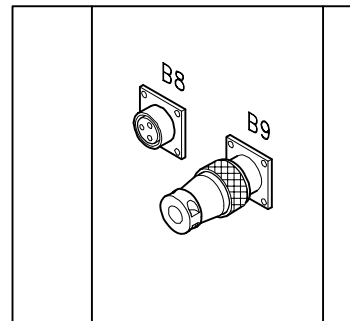
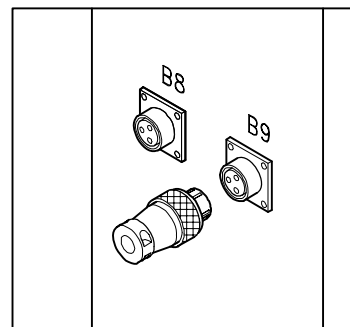
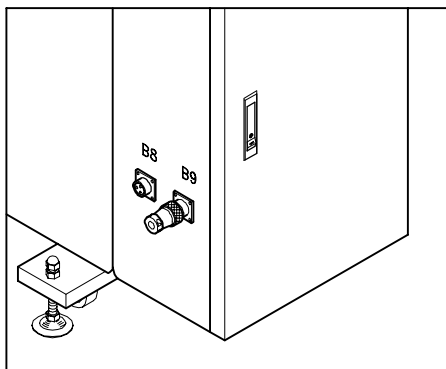



























### (2) B9 Connector (for downstream machine):

Pin 1 and Pin 2: To receive the signal from the downstream machine to pass through the package (Refer to 11. wiring Diagram of PART I).

If there is no downstream machine, please still plug in the B9 connector to avoid machine waiting for this signal which will cause the transit belt not running after the strapping cycle is completed.





shape	classification	shape	classification
	HBS		ER
	TMS		RR
	PMS		SR
	FMS		SP
	HB		BR
	THS		MB
	HSS		KYA
	CAP		KYB
	HN		KYC
	WN		HBW
	FLG		PWA 8x 12~ 16x0.4~0.8t 6x 13~ 14x0.8~1.5t
	NTE		PWB 8x 14~ 16x1.3~1.5t 6x 15~ 16x1.0~1.5t
	PN		PWC 8x 20~ 23x2.0t 6x 16~ 19x2.0t
	PW		PWD
	SW		DS
	TW		TTP
	BWW		FTP

This bill of material, with the aid of illustrations, all the parts used in the TP-601A/B/BP series. When ordering, kindly submit a list using the descriptions, part no.s, and quantities as indicated.

### EXPLANATION OF BILL OF MATERIAL

The following instructions are designed to assist you when ordering parts.

1. The parts are illustrated, with indication of their part no.s.
2. As far as the contents or the book are concerned, only the assembly parts are described, e.g. unit, group, set, etc.
3.
  - (a) If you want to order the control unit on page 1, please indicate the no. at the top of the page. (T6-1-90005, T6-1-90006, T6-1-90008, T6-1-90009)
  - (b) If you would like to order the tension group (in the control unit), indicate the no. on page 1 corresponding to tension group. (T6-1-60003) For further details on the tension group see page 19.
  - (c) If you would like to order the whole tension arm assembly, then indicate no. (T6-1-61001) on top of page 21.
  - (d) If you would like to order a tension jaw spring only, then indicate the no. corresponding to the spring on page 21. (T6-1-61140)
4. Part no.s are to be understood as follows (parts exclusively used for TP-601A/B/BP series machine.)

Please find T6-1-10110 as an example below:

T6.....	MODEL NO.(TP-601A/B/BP)
1.....	UNIT NO. (CONTROL UNIT)
10110.....	PART NO. (TENSION CAM)