

# FULLY-AUTO STRAPPING MACHINE

MERCURY TRANSIT

# TP-702

## OPERATION, SAFETY & SPARE PARTS MANUAL

**IMPORTANT**  
*Keep it*

**TP-702B** (Belt-driven table)

**TP-702BP** (Belt-driven table with compression press)

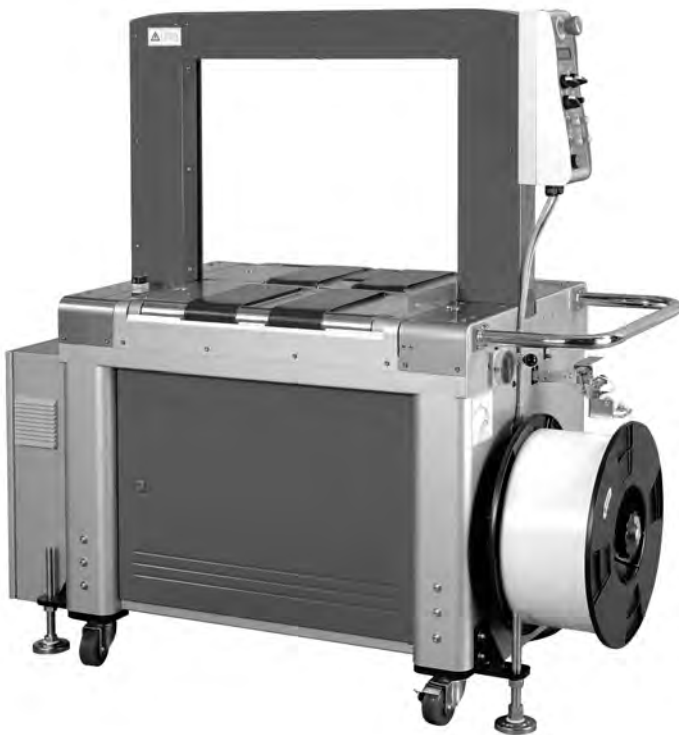

TP-702B

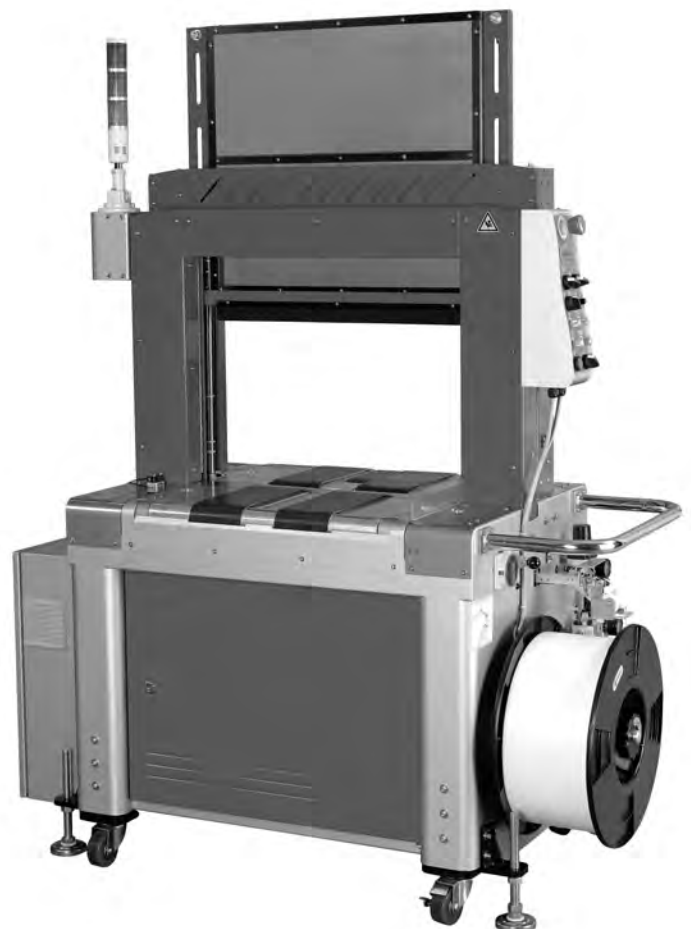

TP-702BP



Made in Taiwan

Read All Instructions Before Operating This Product

**Original Instruction**

# CONTENTS

## **PART I**

1	General Safety Instructions .....	A1
1.1	Basic Operation.....	A1
1.2	Basic Safety Precautions .....	A1
1.3	Safety Instructions Governing Specific Operational Phases.....	A2
1.4	Warning of Electrical Dangers .....	A3
1.5	Grounding Instructions Shall Include the Following .....	A3
1.6	Before Operating.....	A4
1.7	During Operation .....	A4
1.8	After Operating .....	A4
1.9	Signs and Symbols .....	A5
2	Machine Information .....	A6
2.1	Areas of Application .....	A6
2.2	Environment Information.....	A6
2.3	Storage .....	A7
2.4	Machine Description .....	A7
2.5	Safety Devices.....	A8

2.6	Technical Specification .....	A9
3	Preparation Before Operating the Machine.....	A12
3.1	Shipping .....	A12
3.2	Transportation & Centre of Gravity .....	A12
3.3	Construction Layout.....	A13
3.4	Installation.....	A14
3.5	Operation Space .....	A15
3.6	How to connect Upstream and Downstream Machine (B5 Connector).....	A16
3.7	Operating Elements.....	A17
3.8	Instructions for Loading PP Strap .....	A19
3.9	Auto Strap Feeding Procedure .....	A20
4.	Operating the Machine.....	A23
4.1	Manual Operation mode.....	A23
4.2	Transit Operation mode.....	A24
4.3	Automatic Operation mode .....	A24
4.4	Function Encoder .....	A25
5.	Adjustments .....	A26
5.1	Strap Amount in the Accumulator Box .....	A26
5.2	Adjustment for Feeding Pressure to the Accumulator Box.....	A27

5.3	Adjustment for Heater Temperature.....	A28
5.4	Some adjustments for straps .....	A28
5.5	Adjustment for Feeding/Reversing Pressure.....	A30
5.6	Adjustment on Tensioning Rollers for High Tension.....	A32
5.7	Speed and Pressure Adjustment of Press Bar.....	A33
5.8	Change Bundle Flow Direction.....	A34
5.9	Height Adjustment of Press.....	A34
6.	Troubleshooting .....	A35
7.	Maintenance.....	A38

## **PART II**

1	Pneumatic System Diagram.....	B1
2	Wiring Diagram .....	B2
3.	Inverter Parameters Setup .....	B33

# PART III

1. Strapping Head Unit .....	C1
2. Bandway Unit .....	C45
3. Accumulator Unit .....	C73
4. Reel Control Group .....	C97
5. Body Frame Unit .....	C111
6. Electric Control Unit .....	C129
7. Transmission Unit .....	C145
8. Pneumatic Unit .....	C171

# PART I

# 1 General Safety Instructions

## 1.1 Basic Operation

- Read the operation and safety manual prior to using the strapping machine.
- The operation and safety manual should remain attached to the machine at all times.
- The machine may only be operated in accordance with its designated use.
- The strapping machine was built in accordance with state-of-the-art standards and recognized safety rules. Nevertheless, improper use can still result in injury to personnel or damage to the machine and other material property.
- Machine shall only be operated by trained personnel.
- Perform inspections and maintenance at regular intervals. Refer to the Maintenance section of the manual.
- The machine may not be put in operation before checking the respective devices.
- Safety devices must never be bridged or eliminated by any means.
- To transport the equipment only use lifting apparatus and loading devices with sufficient capacity.
- Always disconnect from external power supply when changing the location of the machine, even if the location should only be slightly changed. Connect power supply properly before returning to service.
- Do not alter or bypass protective interlocks.
- Do not alter circuits and machine unless authorized to do so by the manufacturer.

## 1.2 Basic Safety Precautions

- In addition to the instructions for operation, the user is to be instructed in all generally applicable legal or mandatory regulations relevant to safety or the environment.
- Long hair, loose-fitting garments, or jewelry can be a safety hazard. These items must be secured prior to equipment operation.
- Use protective equipment whenever appropriate or when required by law.
- Carefully observe all safety instructions and warnings attached to the machine. Keep safety labels clean and legible.
- People that are being trained to operate or service the equipment must be supervised by experienced personnel.
- Any electrical work performed on the equipment must be conducted by a skilled electrician or under the supervision of a skilled electrician. All work must be observed good electrical engineering practice and follow safety rules and local wiring standards.

### **1.3 Safety Instructions Governing Specific Operational Phases**

- Avoid unsafe operation of the equipment.
- The machine is only to be operated when it is in good running order. Only operate the equipment in a safe manner; all protective and safety devices must be in place and fully functional. This includes removable safety devices, emergency shut-off equipment, noise-protection devices and exhaust fans.
- The machine is to be checked for damage and defects at least once each work shift. Any changes, including the working behavior of the machine, are to be reported immediately. If necessary, the machine is to be stopped and locked-out immediately.
- In case of a malfunction, the strapping machine is to be immediately stopped and locked-out until the fault has been eliminated.
- Before starting the strapping machine, make sure that the area is clear and safe.
- Do not place any tools or parts onto the machine.
- Operating personnel needs to be well trained before executing special operations and maintenance work; this work needs to be done with the proper supervision.
- Always check and tighten connections after maintenance or repair.
- After completing maintenance or repair, all safety devices must be replaced and checked for functionality before operating the equipment.
- To minimize the environmental impact, all consumables and replaced parts must be disposed of safely.
- Before starting the machine, check that the accessories have been stowed away safely.
- Avoid operating the machine in a fashion that could upset its stability.



## 1.4 Warning of Electrical Dangers

- Immediately remove power to the machine in case of trouble in the electrical system. Replace a fuse with one with the same style and ratings; pay particular attention to matching the specified current.
- Any electrical work performed on the equipment must be conducted by a skilled electrician or under the supervision of a skilled electrician. All work must be observed good electrical engineering practice and follow safety rules and local wiring standards.
- Inspect the electrical equipment of the machine at regular intervals. Tighten any loose connections. Check wiring for scorch marks; replace scorched wiring and determine and correct the reason for the overheating.
- When working on live equipment, ensure that a second person is available to cut power in case of an emergency. When appropriate, secure the working area with safety tape and a warning sign. Use insulated tools for electrical work.
- Before working on high-voltage assemblies, turn off the power supply. Carefully discharge the supply cable and short-circuit any energy-storage components such as capacitors.
- If the equipment was moved, carefully refit and refasten all parts removed for transport before reapplying power.
- Before moving the machine, remember to disconnect the power cable.

## 1.5 Grounding Instructions Shall Include the Following

- This product must be grounded. In the event of an electrical short circuit, grounding reduces the risk of electric shock.
- If repair or replacement of the cord or plug is necessary, connect the ground wire to the ground terminal of the plug. The wire with green insulation (with or without yellow stripes) is the grounding wire.
- Check with a qualified electrician or service person if the grounding instructions are not clear or if in doubt about the proper grounding of the machine. Do not modify the plug provided; if it will not fit the power outlet, have the proper outlet installed by a qualified electrician.

**DANGER!**

**Improper installation of the grounding can result in electrocution.**

## 1.6 Before Operating

- Read the instruction manual before operating the machine for your safety.
- Wear eye protection and safety gloves before operating this machine.



Eye protection must be worn



Safety gloves must be worn

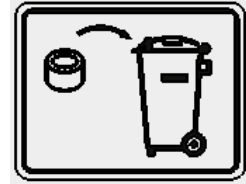

Throw out the spacer from the Reel

- Please take out the spacer that between the Reel Outer Flange and Inner Flange when you install the machine to prevent the machine malfunctions.
- Verify that the power line voltage is correct.
- The machine must be properly grounded to avoid a shock hazard. All wiring must be in accordance with local wiring standards.
- The strapping machine can only be operated with polypropylene (PP) strapping; do not use polyester (PET) strapping or polyethylene (PE) cord strap.

## 1.7 During Operation

- The weight of the package cannot exceed 35kg.
- The size of the package should not be less than 120 mm(W) × 130mm(L) × 10 mm(H) (4.72 inches × 5.12 inches × 0.39 inches).
- While running, check the unit for any unusual sounds or smoke emissions.
- Keep away from the inside of the arch while the machine is operating; do not put your hands or body into the arch when the machine is running.

**NOTE: It is normal for the heater tongue to smoke during the sealing operation.**

## 1.8 After Operating

- Remove dust and dirt from the unit; pay particular attention to the interior of the arch.
- Turn off the power when the machine is not in use.

**NOTE: Don't spray water or liquids for cleaning the strapping machine.**

## 1.9 Signs and Symbols

Symbol	Meaning
	<p><b>Warning for dangerous voltage!</b> Contact with live electrical parts will result in severe injury or death.</p>
	<p><b>Warning for hot surface!</b> Welding area is approximately 270°C(520°F) Allow sufficient time for the heater to cool down before any work in welding area.</p>
	<p><b>Warning for danger!</b> Do not put your hands or body into arch working area when machine is operating.</p>
	<p><b>Warning for danger!</b> Do not put your hands or body into arch working area when machine is operating.</p>
<div data-bbox="245 1727 708 2002"> <p><b>⚠ WARNING</b></p> <p>Moving machine parts can crush, cut and shear.</p> <p>Disconnect and lockout all power before servicing machine.</p> <p>Failure to follow the above can result in severe personal injury.</p>  </div>	<p><b>CAUTION!</b> Don't access to moving machine parts when machine is running.</p>

## 2 Machine Information

### 2.1 Areas of Application

The strapping machine is to be used for strapping packages, cartons, paper boxes, newspapers, magazines and those materials using a polypropylene (PP) strapping for stabilizing purposes when in transportation. Be careful for rigidity of working materials, and don't try to pack agri-foodstuffs or other such material.

This machine was designed for certain applications only. We strongly recommend that this machine NOT be modified and/or used for any application other than for which it was designed. If you have any questions relative to its application DO NOT use the machine until you have had detail instruction from your dealer.

### 2.2 Environment Information

**The strapping machine shall be installed in the following conditions:**

- Supply voltage: 0.9 - 1.1 nominal supply voltage
- Source frequency: 0.99 - 1.01 nominal frequency
- Ambient temperature: 5°C - 40°C (41°F-104°F).
- Altitude: shall be at altitudes up to 1000m above mean sea level.
- Relative humidity: not exceed 50% at 40°C.
- Atmosphere: Free from excessive dust, acid fume, corrosive gases and salt.
- Avoid exposing to abnormal vibration.
- Don't use machine in dangerous environment.
- Don't use machines in damp or wet locations, or expose them to rain.
- Please provide a suitable illumination around the machine for safety operation.
- Work place of user should have a fire extinguisher or other devices that meet their local safety regulations, and always be careful.
- Internal parts requiring frequent inspection and adjustment, and maintenance areas must be provided with a suitable illumination around the machine.

If there may be harmful gases, fumes or dust generated during heating, user or system integrator must install exhaust system for the extraction of harmful substances.

The exhaust system shall be positioned according to the vent location. Please refer to the figure.

The user should refer to a professional expert or relevant authority to prevent the dangerous substance/ gas emitted by suitable means according to local /national environmental/health codes/regulations.

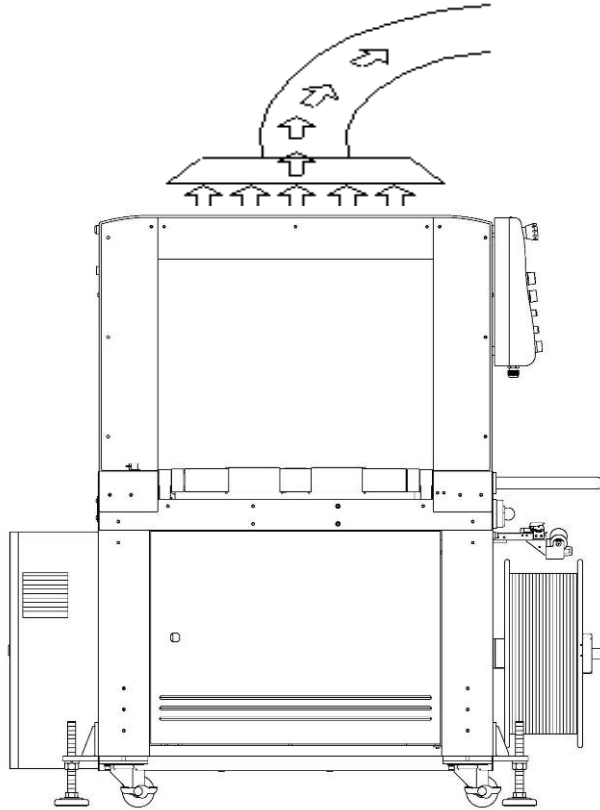

### 2.3 Storage

- The store room must be dry
- Do not expose the machine to extreme cold or heat environment
- Place the machine on an even floor in order to avoid any distortion

### 2.4 Machine Description

- Fully automatic strapping machine for polypropylene (PP) strapping material.
- Transit model with stepless speed belt-driven table
- Electronic heater temperature control.
- Hinged table top.
- Automatic strap loop ejection in case of strapping cycle without package.
- Extra tough construction.
- Simple, safe and user-friendly operation.
- Automatic strap feeding system.
- Automatic strap end detection.
- Mobile, with large table area and high capacity strap reel
- Up and down stream interlock with complete plug connection

## 2.5 Safety Devices



### **Danger!**

**Operate the machine only when all safety devices are at their place and are functioning correctly.**

The machine has been constructed in accordance with the applicable legal regulations. The machine is reliable in operation. Nevertheless the machine may constitute a danger if it is operated in improper or undue condition.

Danger points that cannot be avoided due to equipment design are equipped with safety devices. If necessary, these points are marked on the machine with warning signs, and in the manual under working safety instructions.

The machine is equipped with the following safety devices:	
1.	Warning signs at the danger points of the machine
2.	Automatic shunt down of machine when table top opened
3.	Live parts are secured by cover

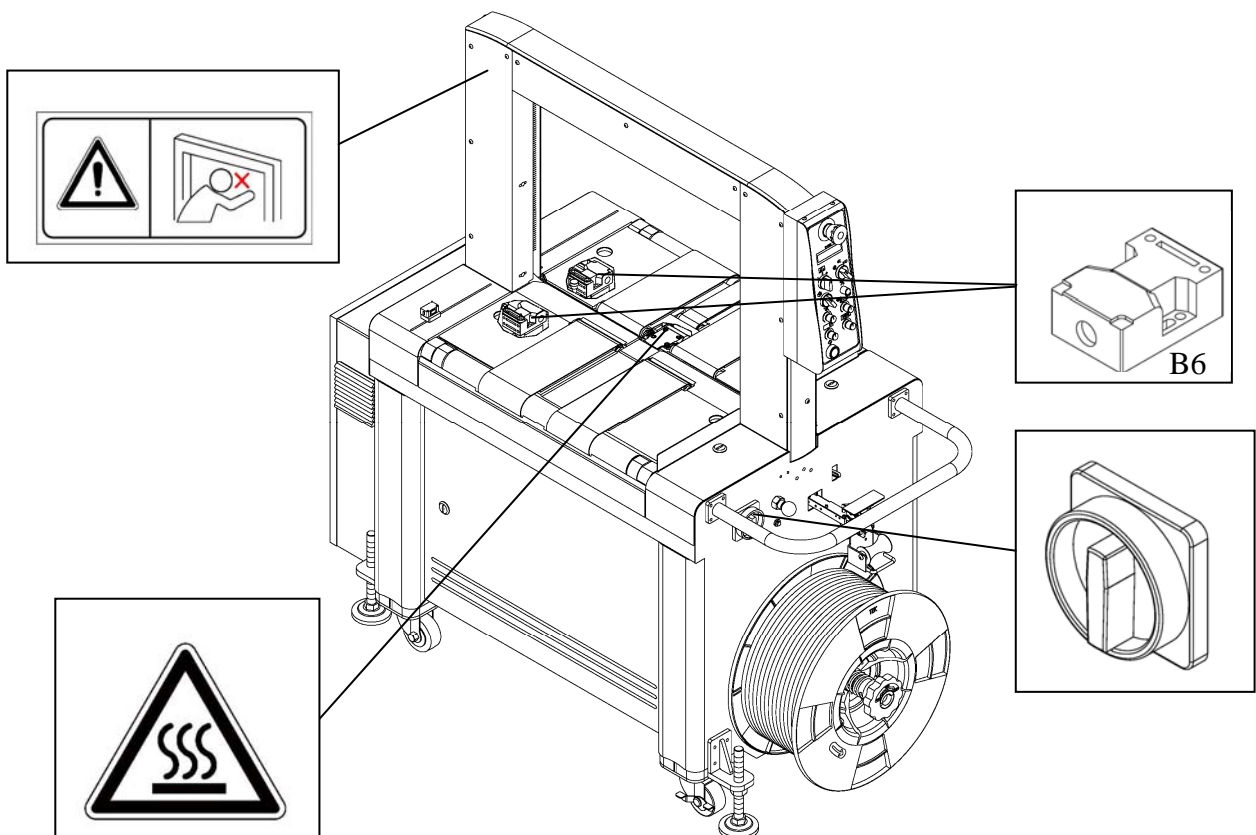

The table top can be opened, if it is necessary to make adjustments inside the machine during operation, after a strap jam for example. When the table top is opened, safety switch B6 is activated. This will remove power but the heating element will keep heating.

**CAUTION!**

**The heating unit operates at a very high temperature in order to melt the PP strapping. To prevent burns, avoid contact with this area.**

**2.6 Technical Specification**

**2.6.1 Electrical Specification**

System configuration:	1L+N+PE (Ground)		3L+PE (Ground)	
Nominal power:	1.0kW		1.0kW	
Rated current:	5A	10A	5A	3A
Rated voltage:	230V	110V	220V	400V
Rated frequency:	50/60Hz		50/60Hz	
Type of current	AC - single phase		AC - 3 phase	

## 2.6.2 Technical Data (TP-702B)

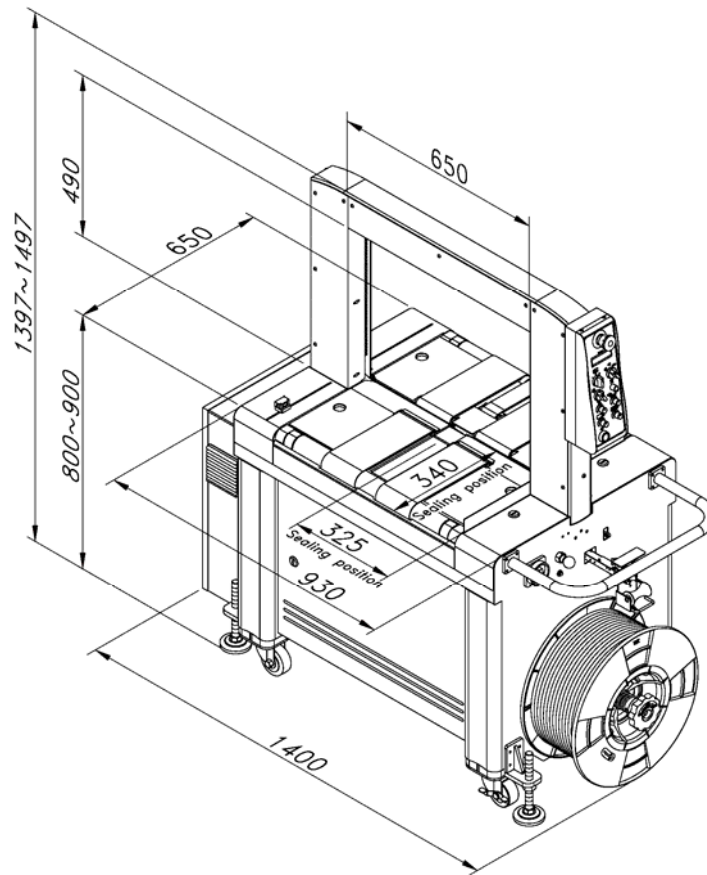

Strap width		5mm / 6mm / 9mm / 12mm
Strap thickness		0.35mm up to 0.65mm (0.014" – 0.026")
Strap coil diameter		Coil diameter 200mm (8" nominal) Outside diameter 420mm (16.5") Width(Face) 190mm (7.5")
Table height	Standard	Minimum – 800mm (31.5") Maximum – 900mm (35.4")
	Optional	Minimum – 750mm (29.5") Maximum – 900mm (35.4")
Weight		225 kg (496 lbs)
Noise emission		78 dBA
Ambient temp		5°C - 40°C (41°F - 104°F)
Minimum package size:		120 mm(W) × 130mm(L) × 10 mm(H) (4.72"W × 5.12"L × 0.39"H )
Maximum package size:		arch size minus 50mm (1.97") EX: arch size: 650W×500H Max. package size: 600mm W×450mm H (23.6" W × 17.7" H)



### 2.6.3 Technical Data (TP-702BP)

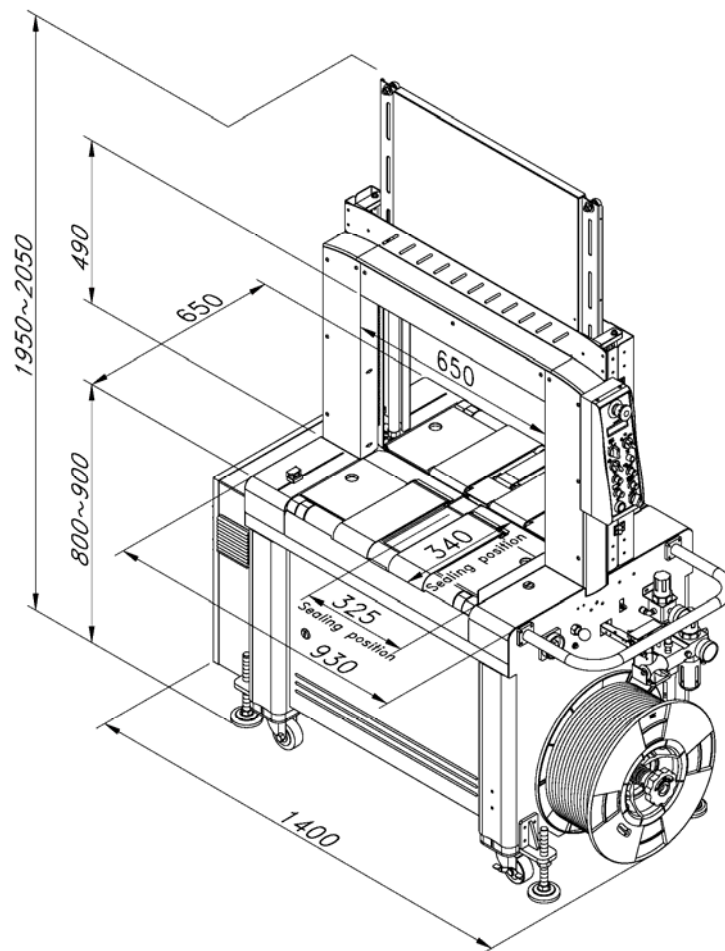

Strap width		5mm / 9mm / 12mm
Strap thickness		0.35mm up to 0.65mm (0.014" – 0.026")
Strap coil diameter		Coil diameter 200mm (8" nominal) Outside diameter 420mm (16.5") Width(Face) 190mm (7.5")
Table height	Standard	Minimum – 800mm (31.5") Maximum – 900mm (35.4")
	Optional	Minimum – 750mm (29.5") Maximum – 900mm (35.4")
Weight		250 kg (551 lbs)
Noise emission		78 dBA
Ambient temp		5°C - 40°C (41°F - 104°F)
Minimum package size:		120 mm W × 130mm L × 10 mm H (4.72"W × 5.12"L × 0.39"H)
Maximum package size:		arch size minus 50mm (1.97") EX: arch size: 650W×500H Max. package size: 600mm W×450mm H (23.6" W × 17.7" H)

### 3 Preparation Before Operating the Machine

#### 3.1 Shipping

The equipment is delivered in transport units. Each transport unit is loaded onto a wooden pallet, secured by polyester strapping.

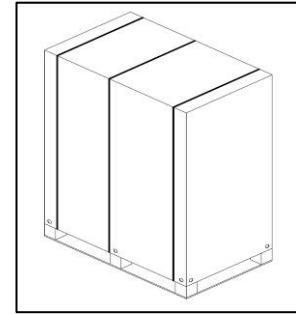

#### 3.2 Transportation & Centre of Gravity

The machine must be secured on a pallet for transportation. A forklift (or other lifting device) is necessary for lifting the machine to the pallet. The casters must fit nicely in the recess on the pallet for proper packaging. Secure the machine to the pallet with plastic strapping across the top plates with a layer of cardboard on it to avoid damage. Cover the machine with sturdy box for protection and hold the whole box to the pallet with plastic strapping.

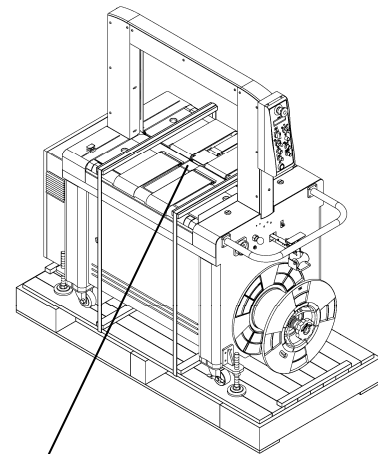

Center-of-gravity position

The machine can be removed from the pallet by using forklift truck or other lifting device.

#### CAUTION!

**Do not carry machine by having the forklift's fork under the arch, but only under the machine frame.**

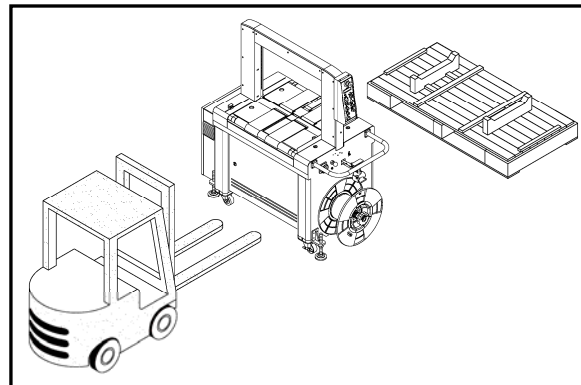
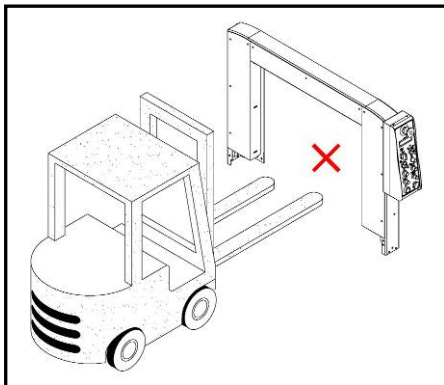

**Danger to Lift!**

Suspend loads can fall down.

By inappropriate mounting or fracture of hoisting device the load can fall down and cause serious injuries or death.

Do not step under suspended loads!

Use appropriate hoisting devices and fasteners.

### 3.3 Construction Layout

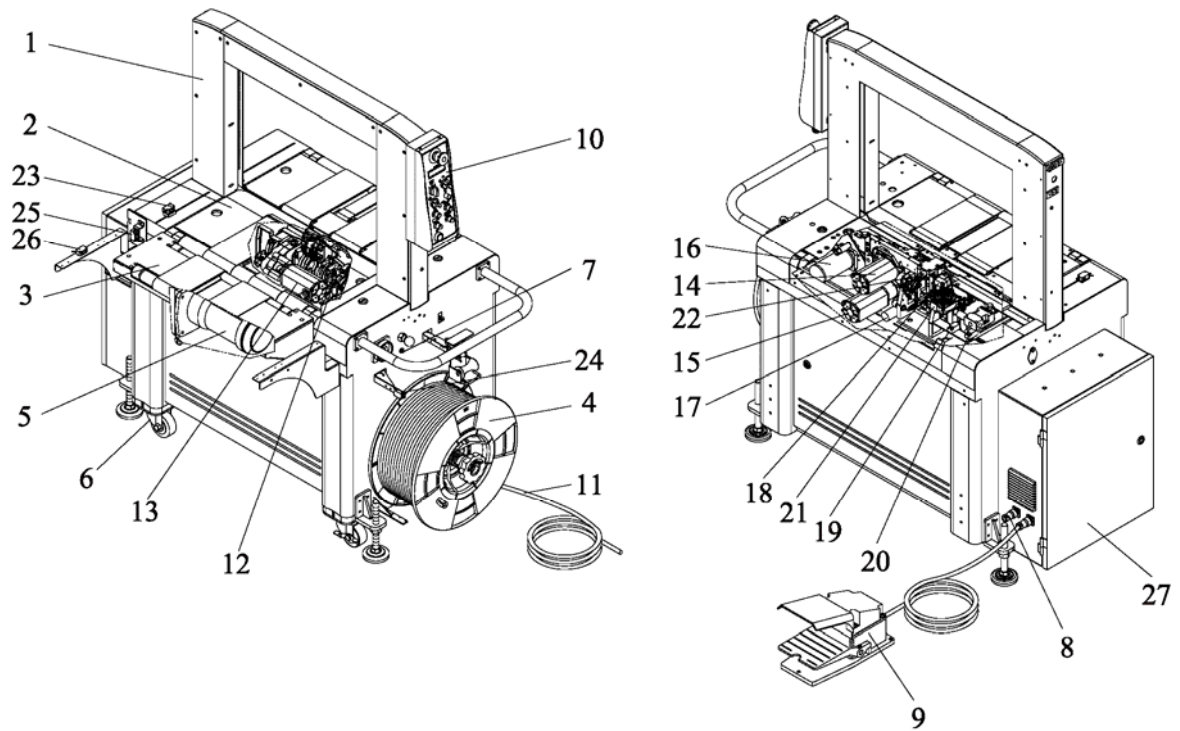

1. Arch
2. Upper Table Front
3. Extension belt-driven table (Option)
4. Reel
5. Transit motor M6
6. Caster (Brake)
7. Reel Brake Release
8. Upstream & downstream interlock (B5)
9. Foot Pedal (Option)
10. Control Panel
11. Power Cord
12. Strapping Head Unit
13. Main Motor M1
14. Feed Motor M2
15. Tension Motor M3
16. Strap Accumulating Motor M4
17. Automatic Feed Motor M5
18. Proximity Sensor SQ1 (For short feed)
19. Proximity Sensor SQ2 (Detects timing lobes on the Position Cam M7-1-112101)

20. Proximity Sensor SQ3 (For home position)
21. Fan (M11)
22. Heater
23. Photo Eye
24. Photo eye (PH3)(Strap amount detection sensor)(Option)
25. Photo eye (PH4)(Energy saving transit with auto sleep mode sensor)(Option)
26. Photo eye (PH5)(Strapping in the centre sensor)(Option)
27. Control box

### 3.4 Installation

1. Remove the packing material and check if the machine is complete without any shipping damage.
2. After positioning it, adjust the machine table height to the same level surface of upstream & downstream equipments by adjusting the machinery pad. After the adjustments, be sure to tighten all the Nuts.

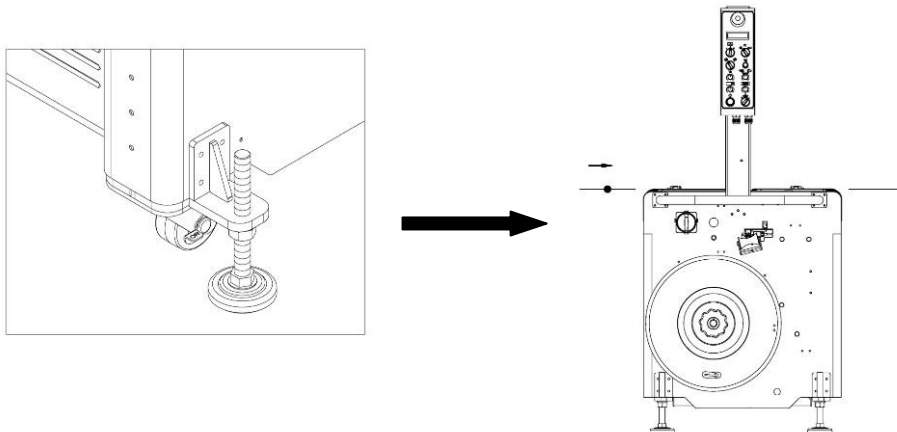

3. Press button A and make light tree stood. (Light tree is option)

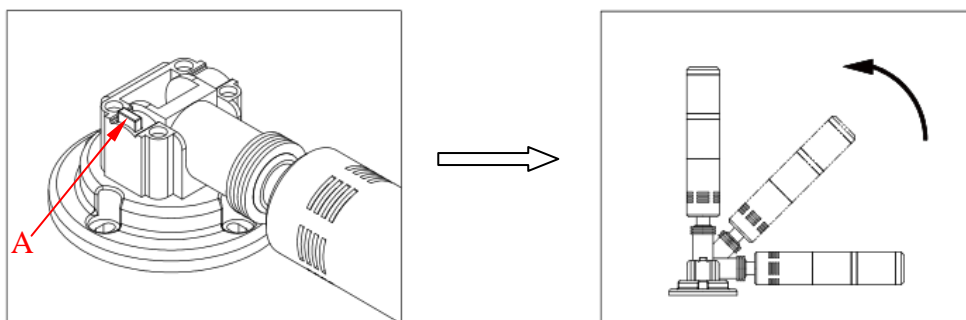

4. The electrical supply cord for the machine must have a minimum cross-section of at least 1.5 mm<sup>2</sup> (16 AWG) and the power cord Length should be less than 500cm.
5. The maximum power line fuse must not exceed 16 Amp.

## 6. Pneumatic connection (for TP-702BP)

- The strapping machines require 3/8" air hose connection (A)
- The operating pressure is 6 bar (87psi), its value is set by the pressure reducing valve (B)
- To alter operating pressure, the knob (B) has to be pulled upward. By turning the knob (B) the pressure can be adjusted. Knob (B) is locked by pressing it down again.

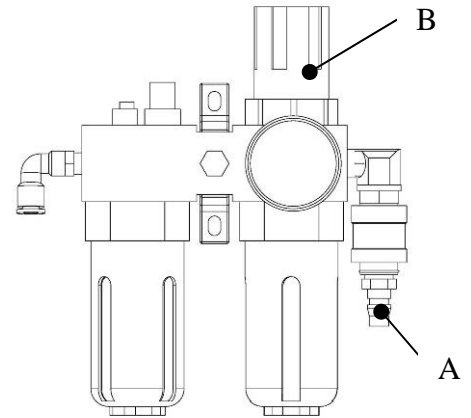

## 3.5 Operation Space

Keep the area (A) and (B) free for the operator.

The area (A) is necessary for operating strapping machine and changing the strap.

The area (B) is necessary for checking the Electricity.

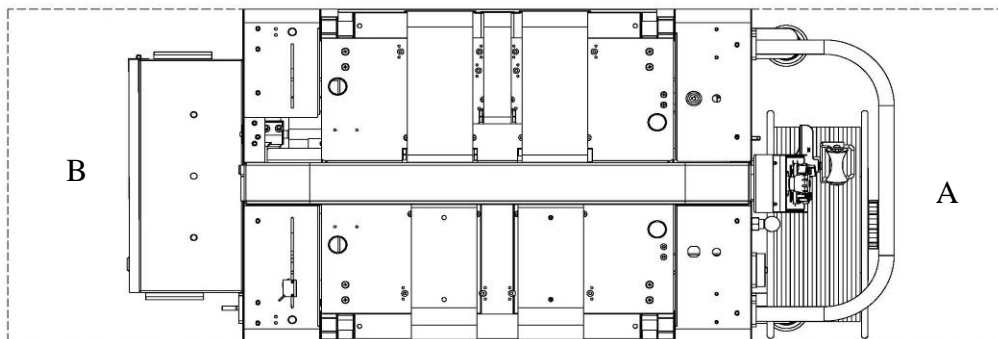

### 3.6 How to connect Upstream and Downstream Machine (B5 Connector)

Pin1 and Pin 2: It outputs machine signal by giving a "NO" contact. Machine would send signal to upstream device for entering the package (Refer to B27 Wiring Diagram of PART II).



**Caution:**

**Mistake the connection (over voltage or current) may damage the K3 relay**

Pin 6 and Pin 7: It is for receiving signals to the machine. To receive the signal from the downstream device for passing through the package after strapping. If there is no downstream device, machine would not pass through the package after strapping (Refer to B27 Wiring Diagram of PART II).

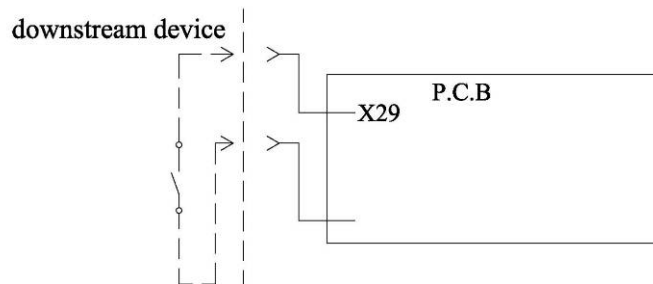

**Caution:**

**The downstream signal should be voltage (potential) free, or it will damage the P.C. Board.**

### **Caution!**

**If there is no downstream machine, please still plug in the B5 connector to avoid machine waiting for this signal which will cause the transit belt not running after the strapping cycle is completed.**

### 3.7 Operating Elements

#### 1. Main Power Switch:

Provides the machine with power.  
Switch to “1” position for turning the machine on.  
After finishing strapping work, switch it to “0” to turn off the machine.

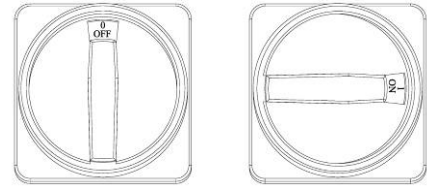

#### 2. Emergency Stop switch



The switch functions for urgently stop the machine. When pressing this STOP switch, the power supply will be shut down immediately. After pressing the switch, it will be locked. For releasing Stop function, just gently turn it clockwise. Remember you still need to press  to let the machine back to normal operation.

#### 3. LCD Display:

Indicates strapping condition of machine and error messages.

#### 4. Selector Switch

This switch is used to select how many (1, 2, or N) straps required for each package.

The selector switch will function only when  selector switch is at position  (AUTO).

#### Note:

When N straps is required for the package. You need to adjust the timer T2 for next strapping until photo eye is off. (PH1).

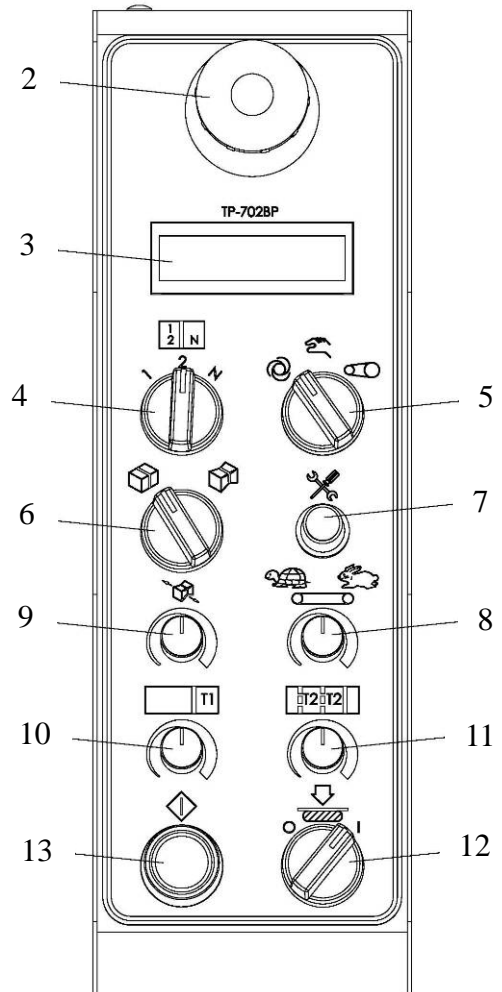

#### 5. Selector Switch

While selector switch is at position  (Manual), table belts will stop running and the photo cells will not function but the machine can strap by pushing the (START) switch.



While the selector switch is at position  (AUTO), the table belts will run and photo cells work so when package passes under the arch, the machine will automatically strap the package.

When the selector switch is at position  (TRANSIT), it is for transit (the table belts will run but the photo cells do not function).

6.   **Soft - High Tension Switch:**

Switch to right (  ) for High strapping tension.

Switch to left (  ) for soft strapping tension.

7.  : **Function Encoder**

Turn clockwise or counterclockwise to change strapping settings.

Also, it offers settings for weld cooling time. Other settings can only be changed by technicians with password.

8.  **TRANSIT SPEED Adjustment Knob**

External adjustment of transit speed by simple turn of a dial. Turn clockwise to increase transit speed; turn counterclockwise to reduce transit speed.

9.  **Strap Tension Potentiometer:**

Turn clockwise to increase strapping tension, turn counterclockwise to reduce strapping tension. This potentiometer is only functional under High tension mode.

10.  **Timer (T1)**

Delay time from the moment that a package is detected until the 1st strapping cycle initiates. It is adjustable from 0 to 5 seconds.

11.  **Timer (T2)**

Delay time (interval) between strap cycles. When multiple strapping cycles are needed, this timer is for an operator to determine the interval between each straps. It is adjustable from 0 to 5 seconds.

12.  **PRESS BAR selector switch (TP-702BP ONLY)**

Bundle press functions only when PRESS BAR selector is set at "1".

Strap without bundle press when PRESS BAR selector is set at "0".

13.  **Start Switch:**

- After turning on **Main Power Switch**, you must press the start switch for machine to get ready for working.
- To initiate a strapping cycle.
- To clear up machine fault. (reset)



**14. Reel Release Switch:**

To release the dispenser for easily taking out the strapping from it.

**15. Foot Pedal Switch (Option):**

To initiate a strapping cycle.  
To clear up machine fault. (reset)

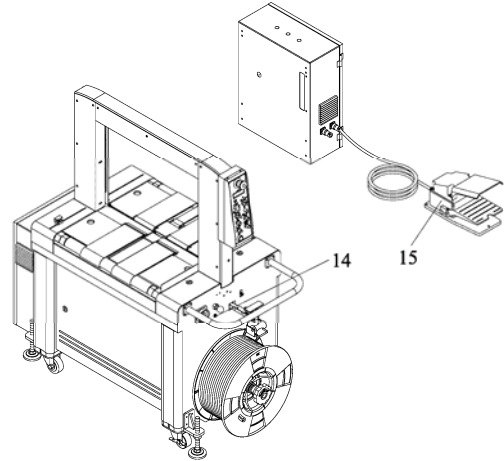

**3.8 Instructions for Loading PP Strap**

**3.8.1 Specifications**

Polypropylene Strap

Width: 5,6,9,12mm

Thickness: 0.35 -0.65 mm (0.014” – 0.026”)

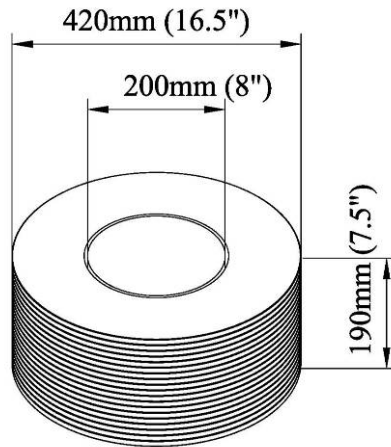

Strap which has excessive camber as illustrated in figure below cannot be used.

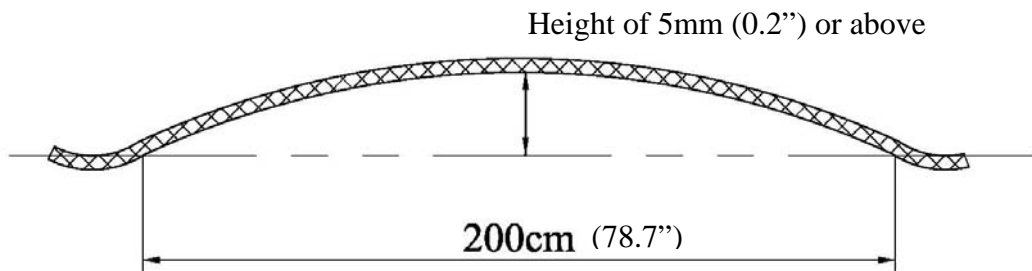

### 3.8.2 Strap Reel Installation

1. Release the Reel Nut Handle by pressing and turning it to the left.
2. Take out the Outer Flange.
3. Install a new strap coil onto the drum according to the instructions on the reel.
4. Put the Outer Flange back and the Reel Nut Handle. Turning the Reel Nut Handle to the right to lock it.
5. Remove the protective straps (B) and the stickers (A)

Note:

The Reel Nut Handle is released by turning to the left. Tighten it by pressing and turning it to the right.

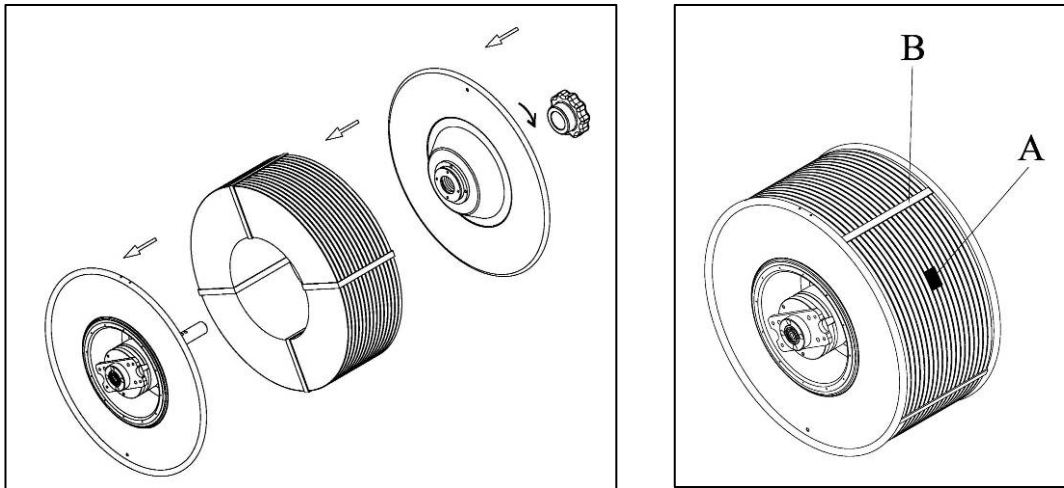

### 3.9 Auto Strap Feeding Procedure

1. Turn the Main Power Switch on the right side of machine to the right (at 1 position), and press Start Switch. (refer to Fig. a)
2. Press “Reel Release Switch A” (as shown in Fig. a) and pull out around 60cm strap. (refer to Fig. b)
3. Thread the strap through the Guide Roller B following to the direction showing in Fig. c.
4. Insert the strap to outlet C (refer to Fig. d).
5. Keep threading until the tip of the strap reaches the Accumulator Main Roller.
6. Lift the lever D and insert strap between the rollers E. Feed strap for around 2-3cm ahead the rollers. (refer to Fig. e)

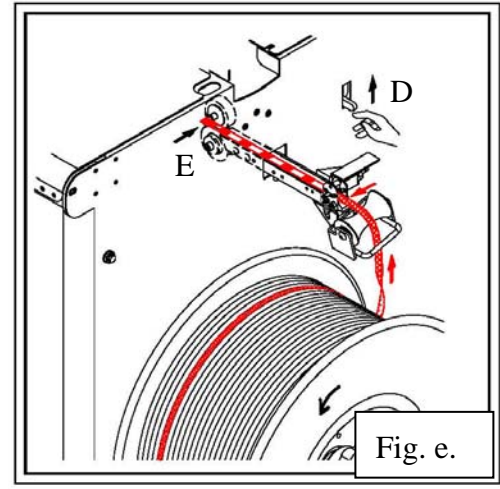
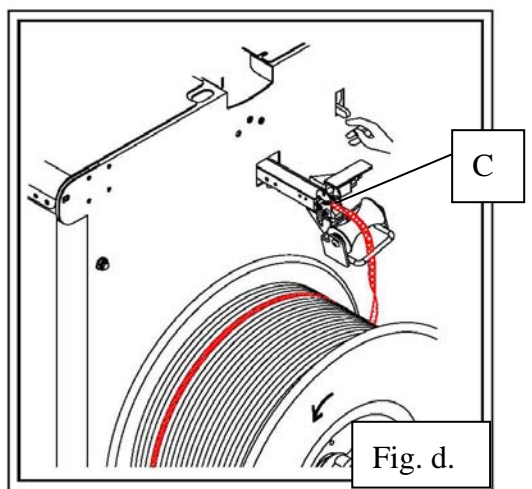
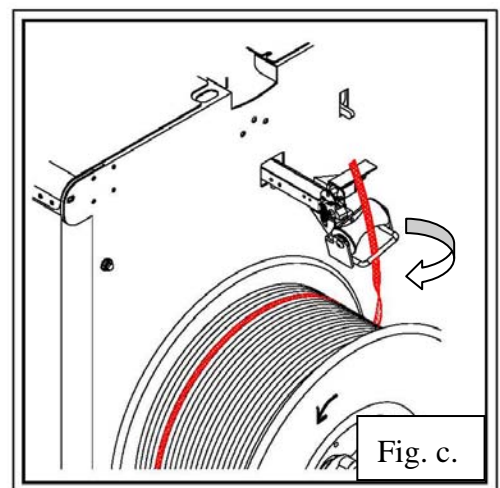
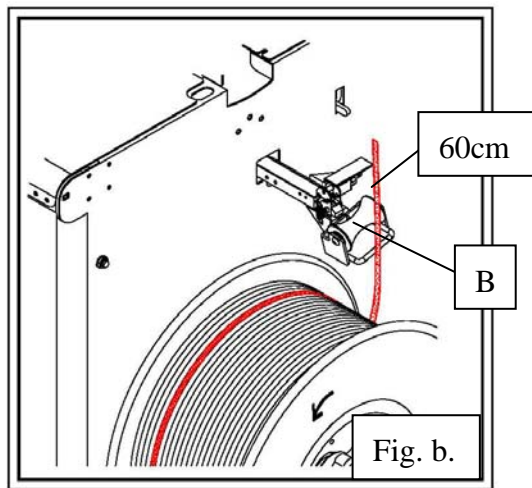
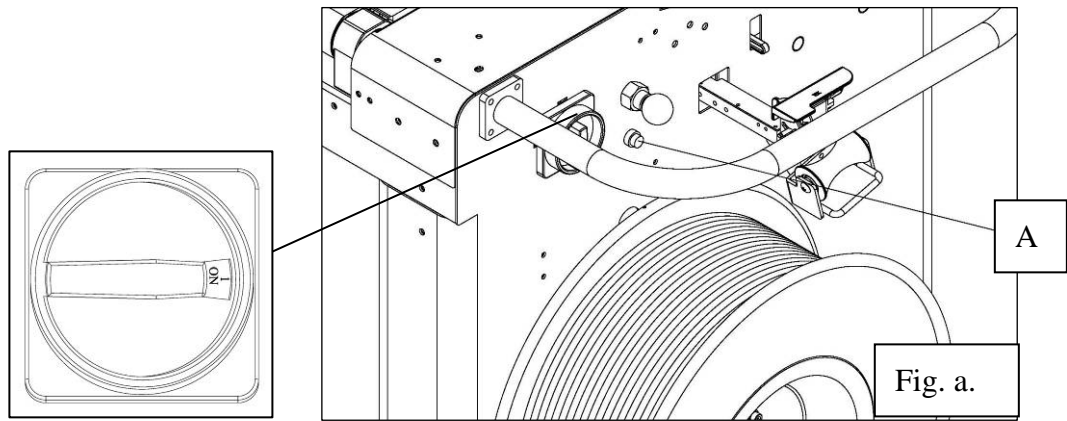

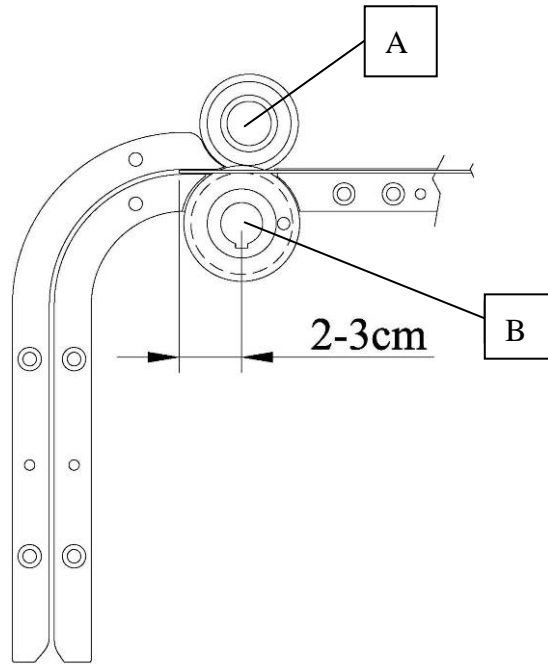

**Caution:**

**If strap is fed more than 6cm ahead the rollers, it could make Auto Strap Feeding failed.**

7. Press Start Switch. Machine will complete the Auto Strap Feeding in 5 sec. and have the strap feeding to the sealing point.

**Caution!**

**In the process of Auto Strap Feeding, only the Start Switch is functional.**

**Caution!**

**The cutting edge of the strap must be free of burrs to avoid failure in Auto Strap Feeding.**

## 4. Operating the Machine

After switching on the strapping machine, heater starts to warm up and LCD display continues to be on until the heater reaches its operating temperature (about 2 minutes).

### Caution!

**Machine will not operate until heater reaches to operating temperature.**

**The heater fans continue to run until heater reaches operating temperature.**

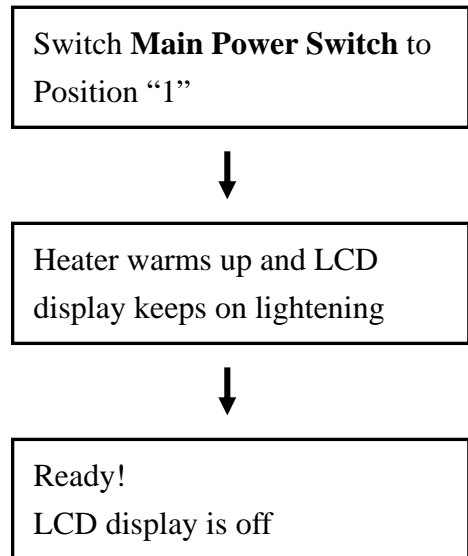

### 4.1 Manual Operation mode

1. Make selector switch to position .
2. Place a package in the middle of table beneath the chute.
3. Adjust selector switch and Tension Potentiometer according to required tension force.
4. Push start switch or foot pedal switch (option) to start strapping.

### NOTE!

**When operating in soft tension mode, the strap tension potentiometer does not function.**



### Attention!

**Keep hands away from the strapping area.**

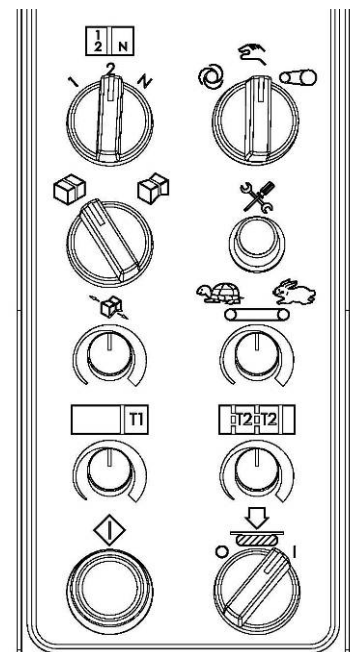
**If hands are caught by P.P. strap accidentally, be sure to turn off the Main Power Switch first and then cut the strap.**



## 4.2 Transit Operation mode





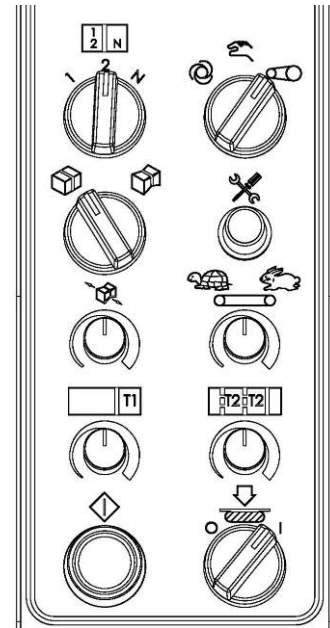

1. Make  selector switch to position .
2. Adjust Transit Speed Adjustment Knob  properly.

### Note !

If there's no signal from downstream equipment, table belts would not run.



## 4.3 Automatic Operation mode

1. Make  selector switch to position .
2. Adjust Transit Speed Adjustment Knob  properly.
3. Adjust selector switch  and Tension Potentiometer according to required tension force.
4. Decide the straps numbers on a package with  selector switch.
5. Switch Press bar selector switch  if required. (Only for TP-702BP)
6. Place package in upstream conveyor and machine would make strapping on the package according to the settings.
7. Move photo cells or make adjustment of T1 or T2 to change the strapping position on the package.

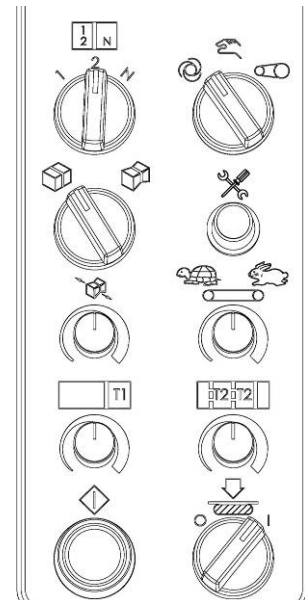

## 4.4 Function Encoder

LCD display will show various timers such as cooling time, timer 1, timer 2...etc. After pressing the function encoder for over 2 seconds, turn the knob to choose the timer needed to be changed. Press this knob to confirm the timer needed altered and turn it again to alter the value, and then press it again to confirm this alteration.

T5: cooling time timer, Range 0-0.6S

T4: Press bar delay time, Range 0-3S

SQ6> 0: sensor for chute home position no function (Disable)  
 1: sensor for chute home position has function (Enable)

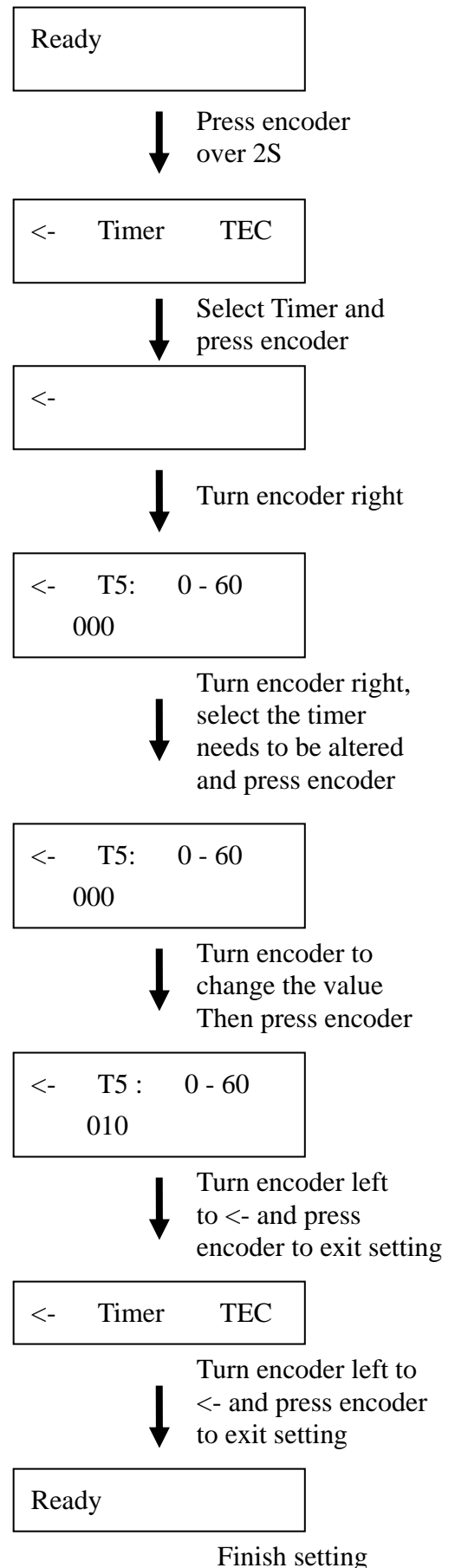

# 5. Adjustments

## 5.1 Strap Amount in the Accumulator Box

The machine has been already well set for storing enough amount of strap in accumulator Box.

However, some adjustments may be required, depending on the actual quality or thickness of the strap used.

The strap supply in the accumulator box should be sufficient for about 2-5 strapping cycle.

(It depends on the package size and the arch size. Fewer cycles are available for bigger arch or bigger package.)

### Caution!

**Excessive amount of strap in the Accumulator Box can lead to strap jam (too curved) and cause feeding problem.**

**Insufficient amount of strap in the Accumulator Box can lead to short feed problem or decrease strapping speed.**

The adjusting mechanism for amount of strap is inside the machine, at the rear side of machine.

In case that there is insufficient amount of strap in the Accumulator Box, loosen the Nut A and turn the Screw Bolt B counterclockwise. After adjustments, be sure to tighten the Nut A to avoid unstable strap accumulation.

In case that there is excessive amount of strap in the Accumulator Box, loosen the Nut A and turn the Screw Bolt B clockwise. After adjustments, be sure to tighten the Nut A to avoid unstable strap accumulation.

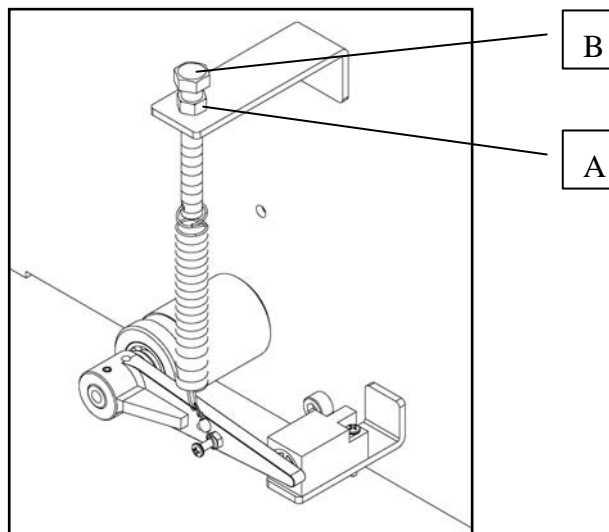



## 5.2 Adjustment for Feeding Pressure to the Accumulator Box

The machine has been already well set for enough feeding pressure offering enough strength for pulling strap from strap coil to accumulator box. It might be necessary for some adjustments to increase feeding pressure if you are using smooth strap.

When it's necessary for increasing the feeding pressure, please loosen the Nut A and turn Nut C upwards to increase the strength of Spring B. Be sure to tighten Nut A by turning it counterclockwise after adjustments.

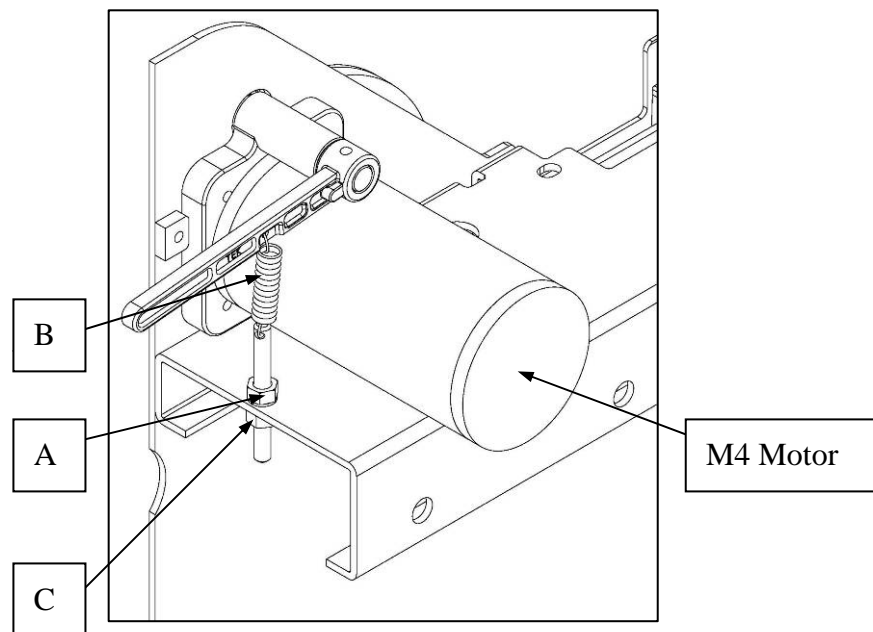

### Caution!

Too much feeding pressure could lead to feeding problem as the strap would be scraped by the rollers easily as show below.

Insufficient feeding pressure would lead to short feed problem as the strap is insufficient in the accumulator box.

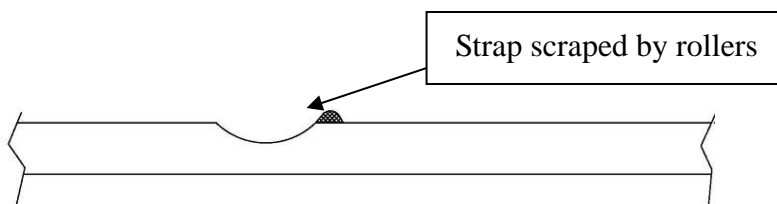

### 5.3 Adjustment for Heater Temperature

The machine has been already well set for proper heater temperature. It might be necessary to do some adjustments according to temperature in working environment, and the quality of PP strap to ensure better sealing efficiency. Turn "A" clockwise to increase the heater temperature and turn it counterclockwise to decrease the heater temperature.

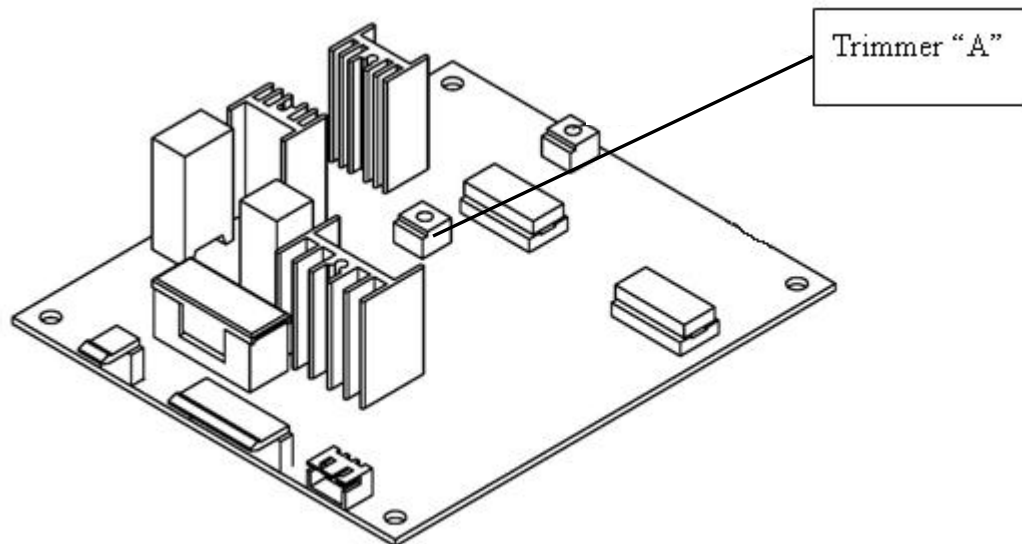

### 5.4 Some adjustments for straps

#### 1. Adjusting "Strap Guide"

Adjusting the A (Strap Guide) according to the strap and make sure the width B is around 0.5mm (0.02") wider than the strap.

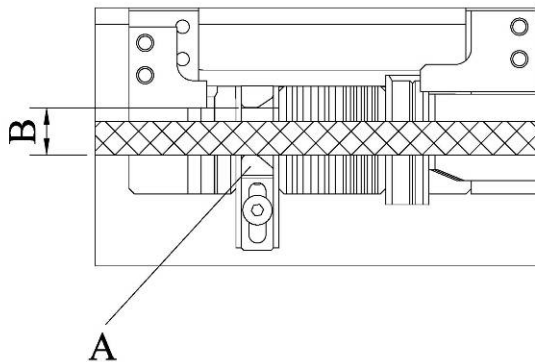

**Caution:**

**If B is too wide, it would lead to sealing problem. However, if it's too narrow, it would lead to feeding problem.**

## 2. Adjusting “Right Strap Guide”

Loosen the screws on the “Right Strap Guide” and take it out. Then loosen the 2 screws B (HBS0408N) and adjust A according to the strap. Be sure D is about 0.1mm wider than the strap. After adjustment, tighten screws B and put the “Right Strap Guide” back.

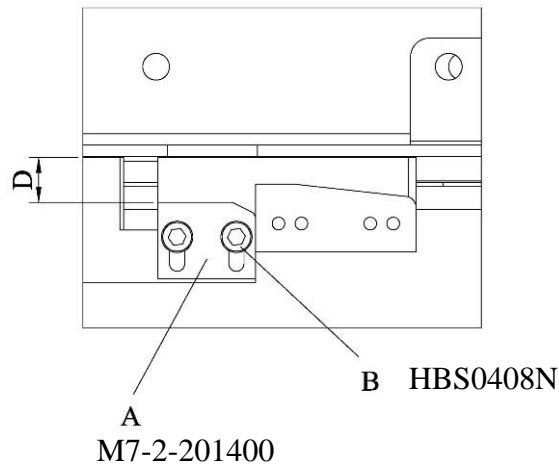

### Caution:

**If D is too wide, it would lead to sealing problem. However, if it's too narrow, it would lead to feeding problem.**

## 3. Adjusting Brush Clearance in the Arch

The brush clearance in the left side and upper left should be about the strap width. The brush clearance in the upper right should be about 2-3mm narrower to the strap.

The brush clearance in upper side of right chute should be the same to the clearance in right side of upper arch. The brush clearance in the lower right should be 4-5mm narrower to the strap.

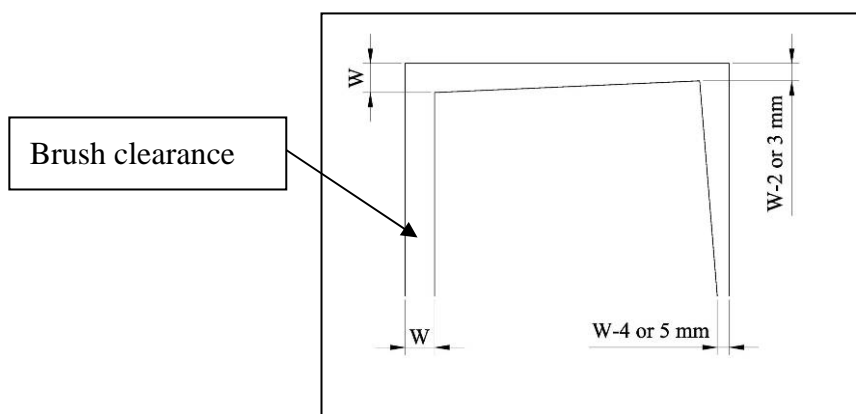

### Note:

The brush clearance could be various according to different package size. The brush clearance needs to be bigger for not having any effect on reversing especially when the package size is close to the arch size.

#### 4. Adjusting Strap Amount in the Accumulator Box

Different strap widths might have effects on the strap amount in the accumulator box. Please do the adjustment according to 5.1 if necessary.

#### 5.5 Adjustment for Feeding/Reversing Pressure

The front and rear table top is fixed and you would need to open it by Key for doing adjustments. The power is shut down once the table is opened as there are safety switches underneath the table top.

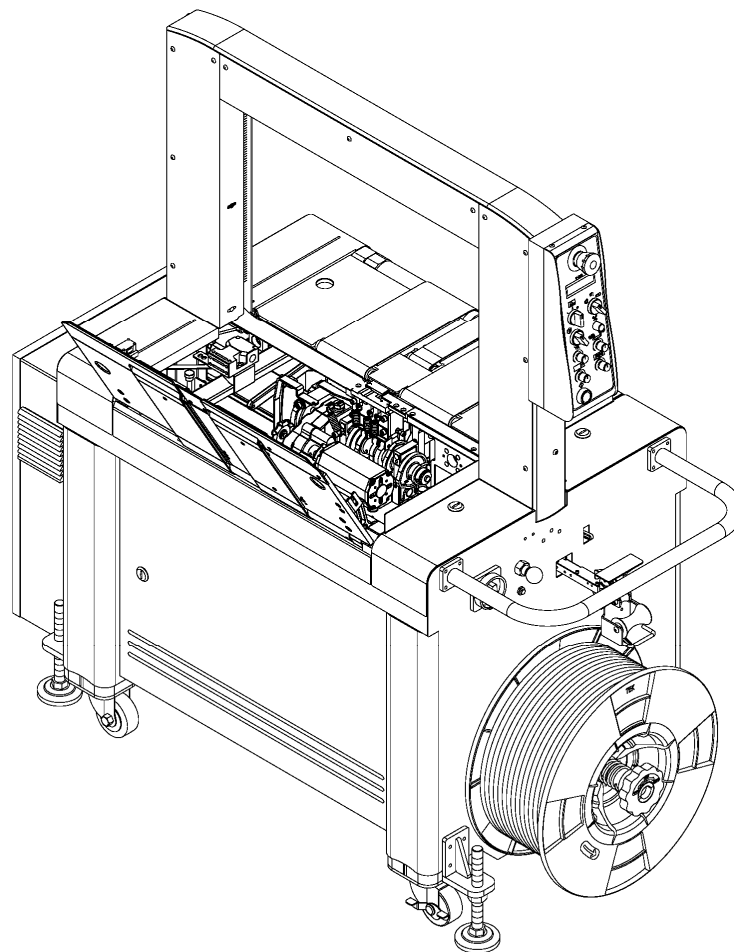

## 1. Adjusting the Pressure for Feeding

The machine is already well set for proper feeding pressure. However, according to different strap characteristics (such as smoother surface or different thickness), some adjustments for feeding pressure are still necessary.

If short feed problem happens a lot, and it is a result of improper feeding pressure, please do the following adjustments:

Loosen Nut B and turn Nut A clockwise to increase the feeding pressure. Or loosen Nut A and turn Nut B counterclockwise to decrease the feeding pressure. After adjustments, be sure to tighten these 2 Nuts well.

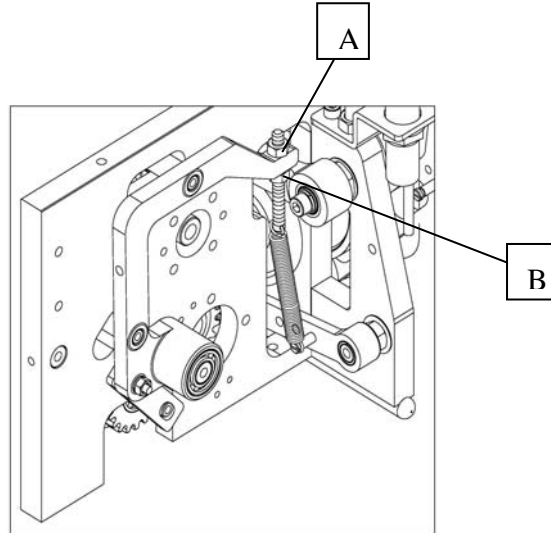

## 2. Adjusting the Pressure for Reversing

The machine is already well set for proper reversing pressure. However, according to different strap characteristics (such as smoother surface or different thickness), some adjustments for reversing pressure are still necessary.

If machine often has incomplete reversing problem, and it is a result of improper reversing pressure, please do the following adjustments:

Take out the part (TA-073 Spring Hook) from C position to B or A position in order to increase the reversing pressure.

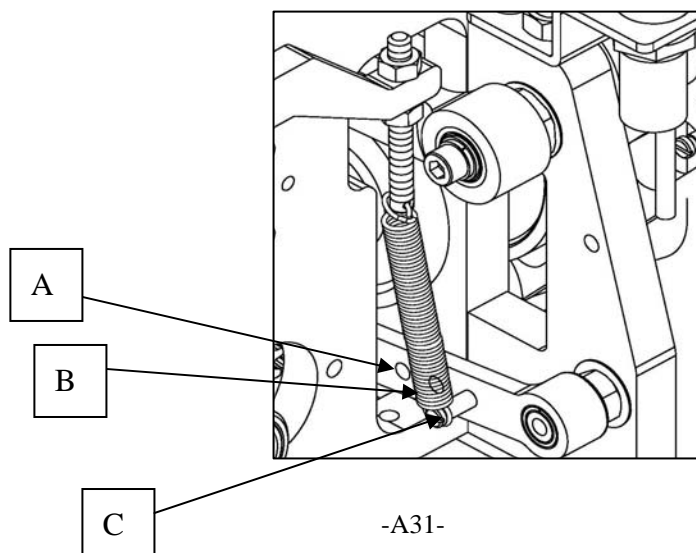

## 5.6 Adjustment on Tensioning Rollers for High Tension

The machine is already well set for proper pressure for high tension. However, according to different strap characteristics (such as smoother surface or different thickness), some adjustments on pressure for high tension might be necessary.

When insufficient strapping tension occurs even the Soft-High tension switch is on “high” position and it is a result of pressure for high tension, please turn Nut D clockwise. This can solve the problem of insufficient strapping tension at high tension and strap slipping between A & B due to this.

**Note:**

**When the pressure for high tension is set too high, the tension for strapping would get lower.**

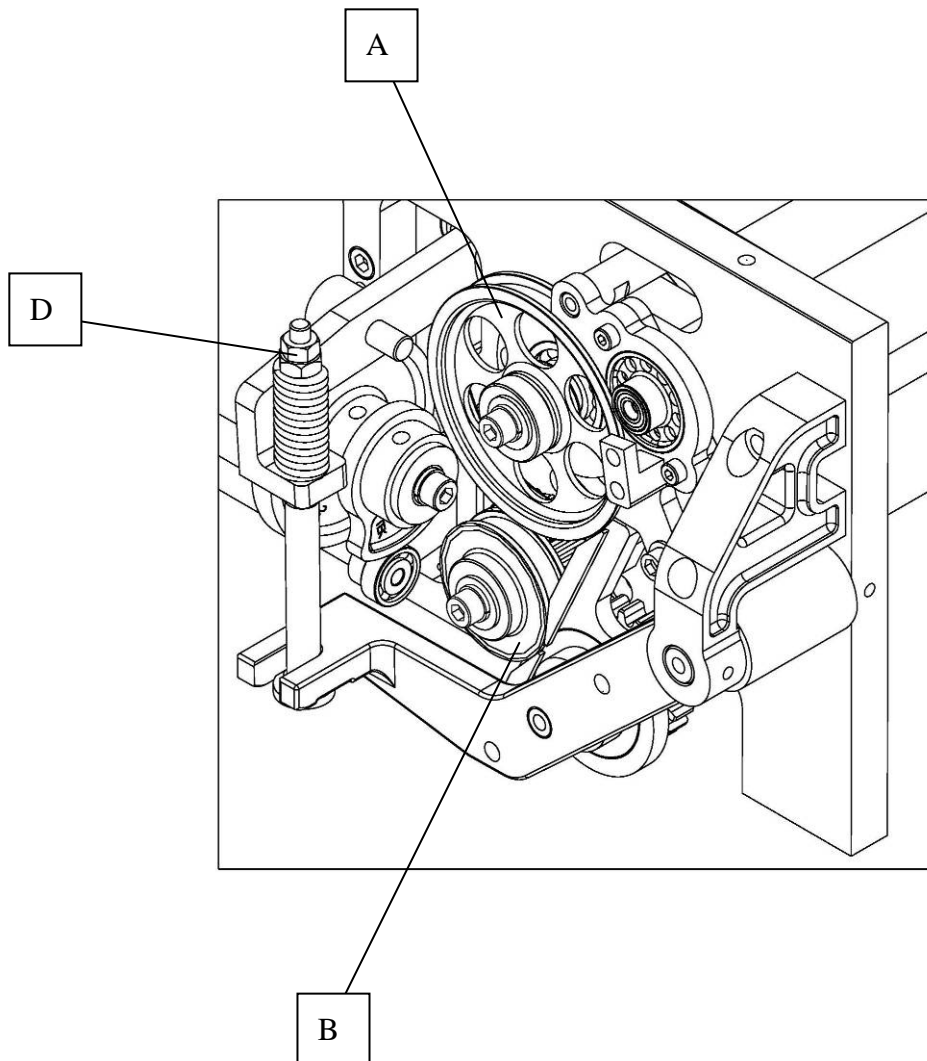

## 5.7 Speed and Pressure Adjustment of Press Bar

### 1. Speed

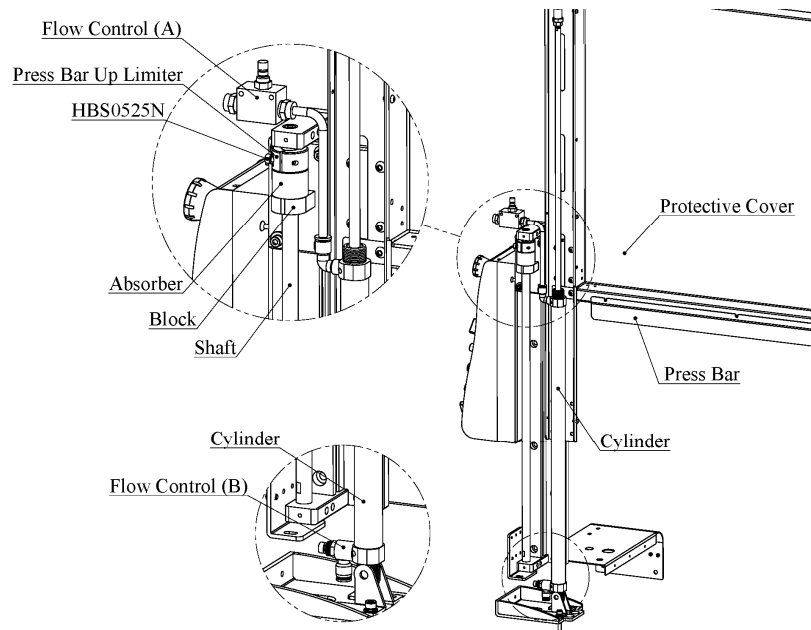

- a. Flow Control (A) : ascending speed adjustment of Press Bar.  
Turn knob counterclockwise to increase the ascending speed of Press Bar.  
Turn knob clockwise to decrease the ascending speed of Press Bar.
- b. Flow Control (B) : descending speed adjustment of Press Bar.  
Turn knob counterclockwise to increase the descending speed of Press Bar.  
Turn knob clockwise to decrease the descending speed of Press Bar.

### 2. Pressure

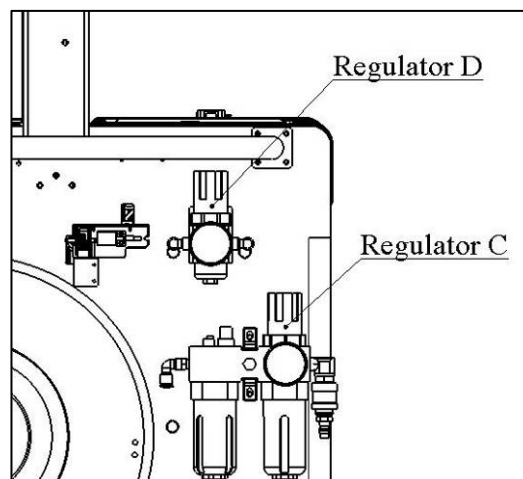

Air pressure adjustment for ascending and descending Press Bar

Regulator C: Adjustment for ascending pressure of Press Bar

Regulator D: Adjustment for descending pressure of Press Bar

For doing these adjustments, be sure to lift the Regulator first and then turn it clockwise to increase the pressure or turn it counterclockwise to decrease the pressure.

**Caution:**

**Regulator D shows the descending pressure only when Press Bar is descending.**

**If the air pressure is exceed 2 bar, the descending pressure of Press Bar would be over 250N.**

**When the descending pressure of Press Bar is over 250N, safety device (such as Safety Guard) would be necessary according to CE regulation.**

## 5.8 Change Bundle Flow Direction

If you need to change the bundle flow direction, please do it as following steps:

- a. Change the phase sequence of M6 motor. (Please refer to B2 / ED1, interchange either 2 wires from frequency inverter to M6 motor)
- b. Change the positions of PH1 and reflector to the other side of arch.
- c. Adjusting the table belts and make sure that they are in the middle to avoid any damage to the belts. You could make this adjustment with screws (#50 FMS0560N) showed in Part III P149.

## 5.9 Height Adjustment of Press

The height for press going upward is adjustable according to different package height.

- a. Remove the pneumatic source and have the press bar descending.
- b. Loosen the cover of both sides.
- c. Loosen HBS0525N on Press Bar Up Limiter and adjust it to required height. Then screw HBS0525N by turning it clockwise.

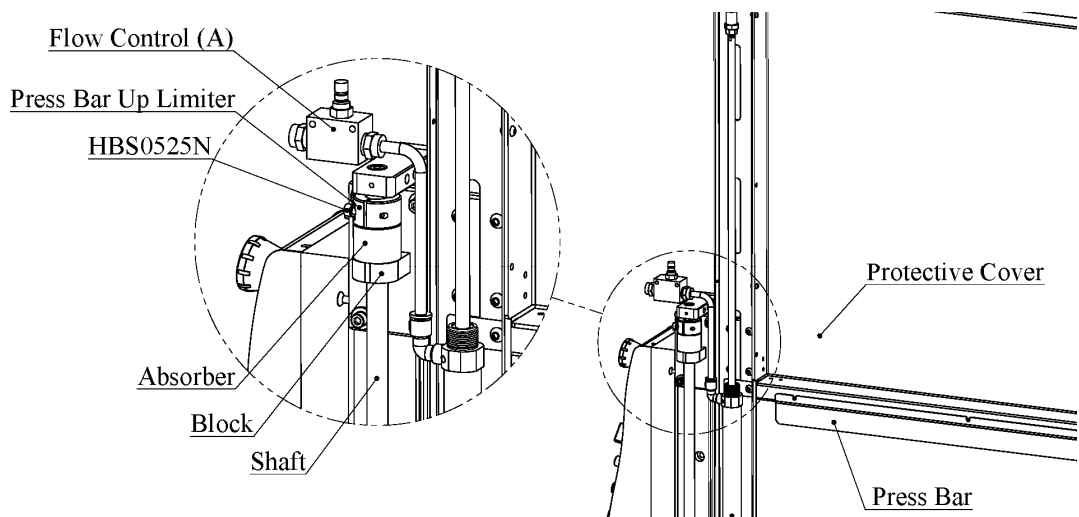



## 6. Troubleshooting

The LCD display would flash and show failure message when machine is not working due to malfunction.

Message shown on the LCD could be follows:

### 1. Reminder message:

- a. Push Start: Please press the Start Switch to make machine function. This is especially necessary after the Safety Switch is released or after you just turn on the machine.
- b. Load Strap: Load a new roll of strap or re-do the Auto Strap feeding again.
- c. B6 open; K1 open: When it shows this message after you press the Start Switch, it means the Safety Switch might not be closed or the K1 in the control box is abnormal.

### 2. Malfunction from switches:

- a. S1 Error: This means the Start Switch or the Foot Pedal is continuously triggered before activating them. Please check if any of these 2 Switches is defective.
- b. S5 Error: This means the Reel Release Switch is continuously triggered before activating it. Try to press it by hand to see if it's defective.
- c. SQ1 on Error: The SQ1 is triggered when doing Auto Strap Feeding. Check if the SQ1 or the Switch lever is defective.
- d. SQ9 failure: Foot bar is not able to function properly and cause it not able to go back to home position.

### 3. Malfunction from procedures:

- a. ASF failed: Auto Strap Feeding failed. It might be caused by wrong inserting direction or inserting too much strap. Please re-do the Auto Strap Feeding.
- b. Feed jam: Resulting from not being able to feed strap to the sealing position.

When Feed jam occurs, press the Start Switch or Foot bar first to let the arch open and strap comes out of the arch. Hold the strap by left hand and then press the Start Switch or Foot bar again. Machine would reverse the strap a little bit and cut it, and then machine would go back to home position and feed again.

If this does not solve the problem, please take out the jammed strap by following

steps:

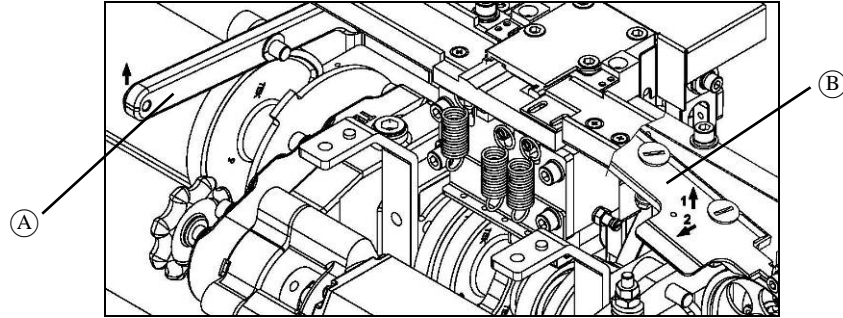

- b-1. Open Upper Table, Front Group M7-7-100230.
- b-2. Lift up the Lever (A) (M7-2-101400/M7-2-101410) with left hand and take out the Cover (B) (M7-1-311201) for the Upper Guide with right hand at the same time.
- b-3. Take out the jammed strap and cut it.
- b-4. Put the cover (M7-1-311201) for the Upper Guide back to its position and put the Upper Table Front Ass'y back as well. Push START switch in the control panel to RESTART machine.

If the Feed jam problem still cannot be solved, the following causes have to be checked as well:

Fault	Cause	Remedy
Feed jam	Strap is too curved	Change strap
	Insufficient feeding pressure	Adjust feeding pressure according to 5.5
	Too much strap amount in the accumulator box and has caused strap to be curved	Adjust to proper strap amount in the accumulator box according to 5.1

c. Other malfunctions:

Fault	Cause	Remedy
Sealing failure	Too much debris on both sides of heater plate	Clean both sides of the heater plate by fine sandpaper
	Insufficient heater temperature	Increase the heater temperature according to 5.3
	Insufficient cooling time	Increase cooling time according to 4.3
Insufficient strap tension	Soft-High tension switch is at “soft” position	Turn it to “high” position
	Lubricant drops into tension roller incautious	Clean the lubricant
	Too much debris in the gear of tension roller	Clean the debris
Press Bar no function	No air supply	Make sure the air supply is correct.
	Press Bar function is not ON	Enable Press Bar function (refer to 4.3)
	Press Bar is not moving freely	Clean and lubricate it.
	Solenoid Valve is not functional	Replace Solenoid Valve

## 7. Maintenance

### Warning:

**Before any maintenance or repairs on the machine, set the Main Power Switch to "O" (OFF). Wait about 5 minutes for cooling down the heater to avoid burns with this area.**

### 1. Cleaning and Lubrication

The high reliability and long service life of the strapping machine will depend on regular cleaning and maintenance.

#### ATTENTION!

**All the important strap transportation components, such as the drive rollers and the strap guides, must be kept free from oil and grease. (lubricant)**

**The lubricant has to be non-resinous.**

**The lubricant is SAE 30**

### 2. Maintenance

**Only use original spare parts supplied by manufacturer.**



#### Daily:

Use air gun to clean the following indicated positions (nearby the cutters, strap guide and accumulating feeding rollers) daily

Remove plastic residue in the machine.

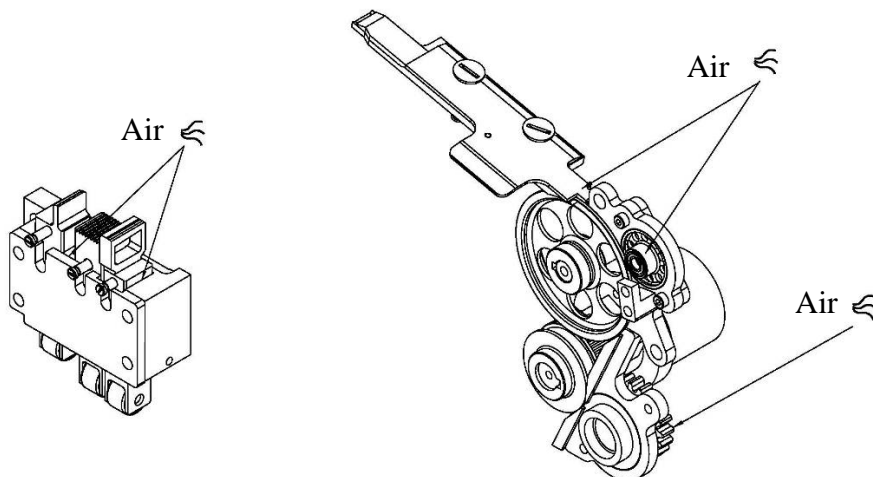

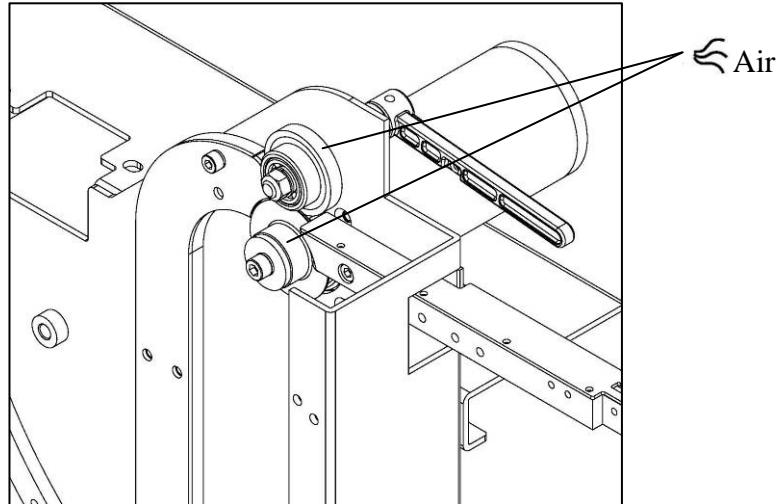

**Weekly:**

Lubricate front bar, press bar, rear bar and shafts in arch weekly.

Please refer to the following mesh areas for instruction.

Before lubricating, be sure to clean the parts first to avoid mixing oil and debris which might have a bad effect on machine's function.

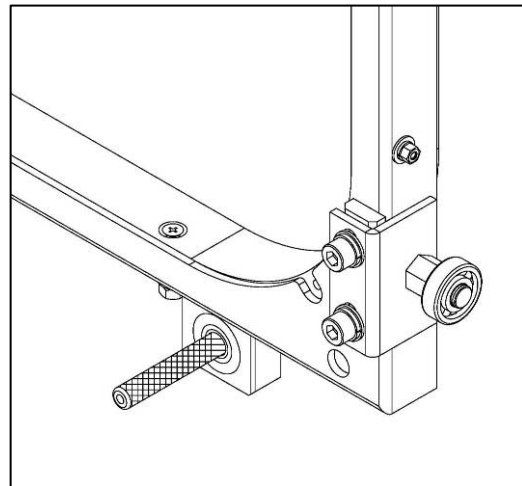
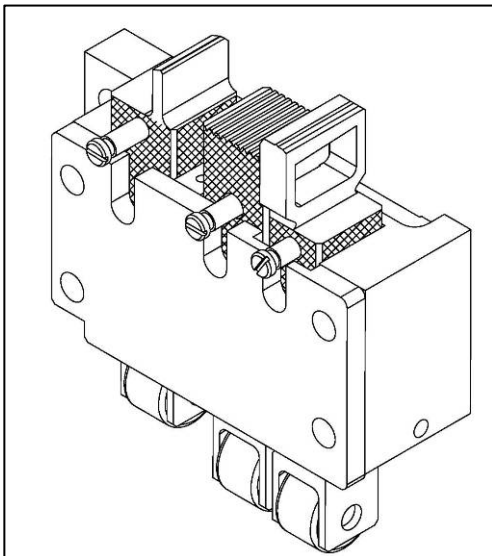

Check the machine by strapping several bundles for any failures.

**Monthly :( or 100,000 strapping cycles)**

Clean both sides of heater plate and polish with fine sandpaper if necessary

**ATTENTION: Make sure the welding plate is cool first!!**

Check Front Bar, Press Bar, and Rear Bar for moving upward and downward neatly. The Slide Table and Strap Track Frame should be able to go back to its home position by the force of spring as well.

Be sure to clean any debris in the tension roller

### **6 Months: ( or 500,000 strapping cycles )**

Check heating element, replace and re-adjust it if necessary.

Check strap cutter in sealing head, replace it if necessary.

Check if the connector at wiring housing to P.C. Board is firmly fixed.

Check if the safety switch of front table or Rear table functions well.

Make machine ready for operation. Strap one bundle manually several times, paying attention to mal-functions, repeat procedure.

Initiating several cyclings with package manually for testing and pay attention to any mal-functions. Make sure the strap accumulating function is well. If necessary, replace the assistant rollers, do proper adjustments to accumulating feeding pressure or to the clearance in the reel brake.

Slightly lubricate the sealing head (bearing points) with light lubricant if necessary.

### **1 year :( or 1,000,000 strapping)**

Replace deflection roller if it shows visible changes.

In case of loud noise at bearings: locate them, replace the bearings.

Get machine ready for operation again, strap one bundle manually several times, paying attention to malfunctions.

## **3. Cleaning / Replacing Heater**

### **Cleaning**

1. Turn off the power and open the Upper Table, Front Group and Upper Table, Rear Group (M7-7-100230 & M7-7-200110).
2. Make sure that the heater cools down already and the temperature is not too hot to let you get hurt.
3. Loosen the fixed screws of the heater cover (M7-1-101720) and remove it from the machine.
4. Remove the screw (HBS0540HN) of Heater Crank (M7-1-141100).
5. Remove the Return Spring (T7-1-64130) of the Heater Crank (M7-1-141100).
6. Remove the Heater Crank (M7-1-141100) by pushing it backward.
7. Clean both upper side and down side of the Heater carefully with fine sander paper.
8. Re-installation the heater back to the machine in reverse sequence.

### **Replacing**

1. Same sequence as step 1-6 mentioned above.
2. Turn over the Heater Bracket (M7-1-141300) so that you can loosen the nuts of the heater.
3. After you loosen the nuts, turn the Heater Bracket back to its original position.
4. Take out the Heater Ass'y and make sure the insulations stay intact. If any of

insulation fall and get broken, please replace with new one to avoid welding problem.

5. Install the new Heater Ass'y in reverse sequence.
6. Rotate the M1 Handle (T7-1-11240) forward till the Heater Ass'y goes to welding position.
7. Make sure the clearance between Heater Ass'y and Slide Table (M7-1-131600) is about 1.8 - 2.2mm.
8. If the clearance is too big, adjust it by turning HBS0530N clockwise. If the clearance is too small, adjust it by turning HBS0530N counterclockwise.