

FROMM

OPERATION MANUAL / SPARE PARTS LIST

BATTERY - POWERED PLASTIC STRAPPING TOOL MODEL P329 M/HA

43.2533.01

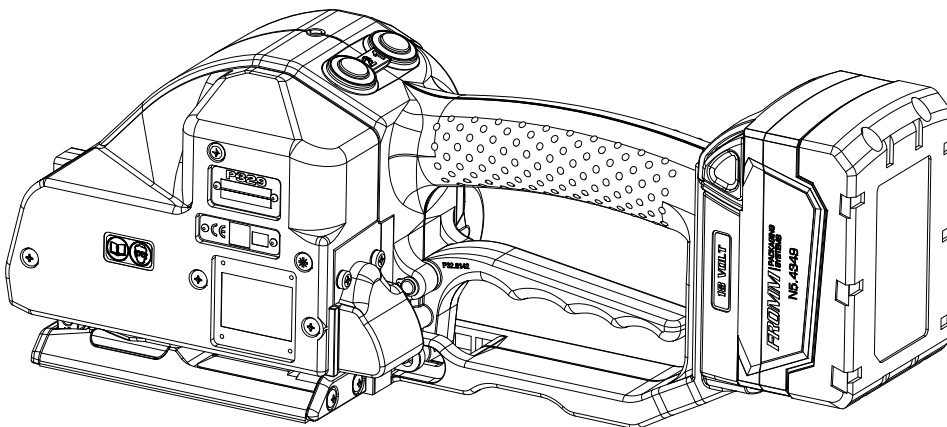

CE Declaration of conformity

We declare that the machine P329
is in conformity with the following standard or
standardised documents:

2006/42/EC,

2004/108/EC

Technical file at:

M.Rauch

FROMM System GmbH

Neulandstrasse 10

D-77855 Achern

06.03.2014

A stylized signature of R. Fromm in black ink.

R.Fromm

Director

FROMM Holding AG

Hinterbergstrasse 26

CH - 6330 Cham



4.7 Wearing plate

As an option, the tool can be equipped with a wearing plate to protect the base from excessive wear on abrasive package surfaces.

The complete wearing plate can be ordered together with the fastening screws under item number P32.0226.

If the complete bottom side of the tool has to be protected, the plate P32.0227 must be used.

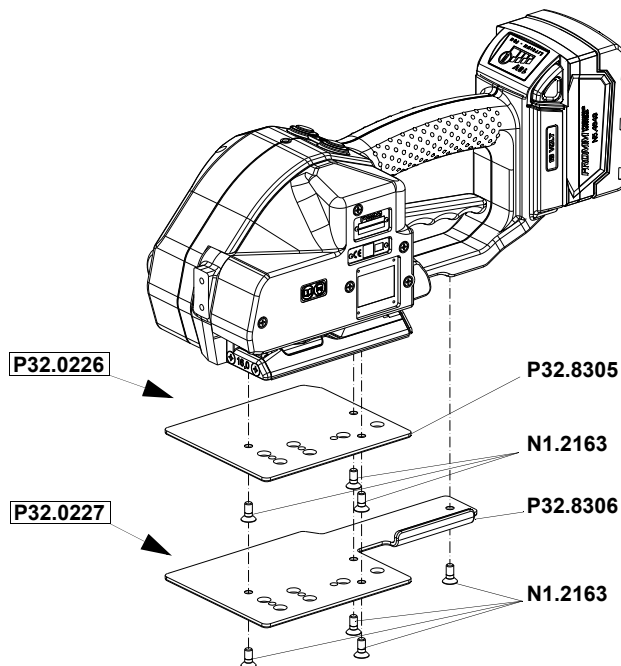

5 OPERATING ELEMENTS

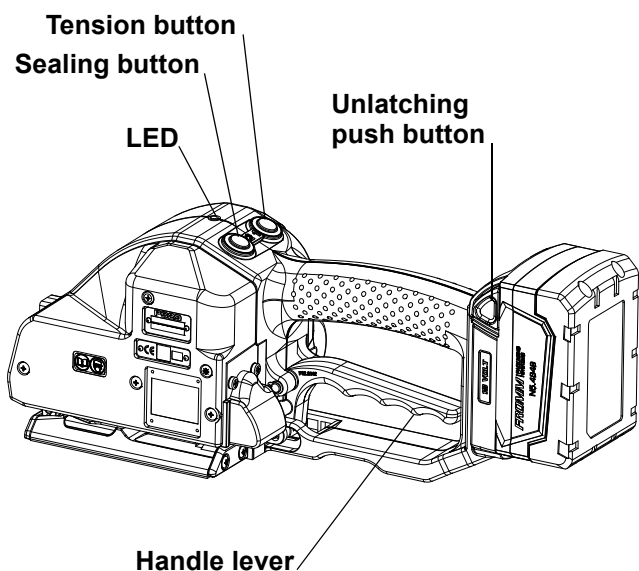

LED - Indication at the tool	
Green	During tensioning the LED lights green.
Blue	Welding is initiated. (only in semi-automatic mode)
Green	During welding the LED lights green.
Yellow	Cooling time is running, the tool must not be removed from the strap.
Blue blinking	Motor overheated, Motor cool down time running. If during this time a switch is operated, an acoustic signal happens.
Green + Acoustic signal	Cooling time is finished; the tool can be removed from the strap.
Red	Charge the battery.
Red blinking	Malfunction: e.g. lowering motor blocked. Remove battery Clear malfunction Insert battery
Without indication	Power saving mode

9 EXCHANGE OF WEARING PARTS



Remove always the battery from the tool before starting maintenance works.

9.1 Exchange of tensioning wheel and grippers

Disassembling

- Unscrew cover P32.0221 and remove it;
- Unscrew end cover P32.0222 and remove it;
- Raise tension wheel P35.3203 by lifting the handle lever P32.8142;
- Remove the tensioning wheel together with the bearing N3.1172 from the tool;
- Unscrew the holder P32.8108 and remove it from the body;
- Remove the grippers (P32.8109, P32.8110, P32.8111) from the body.

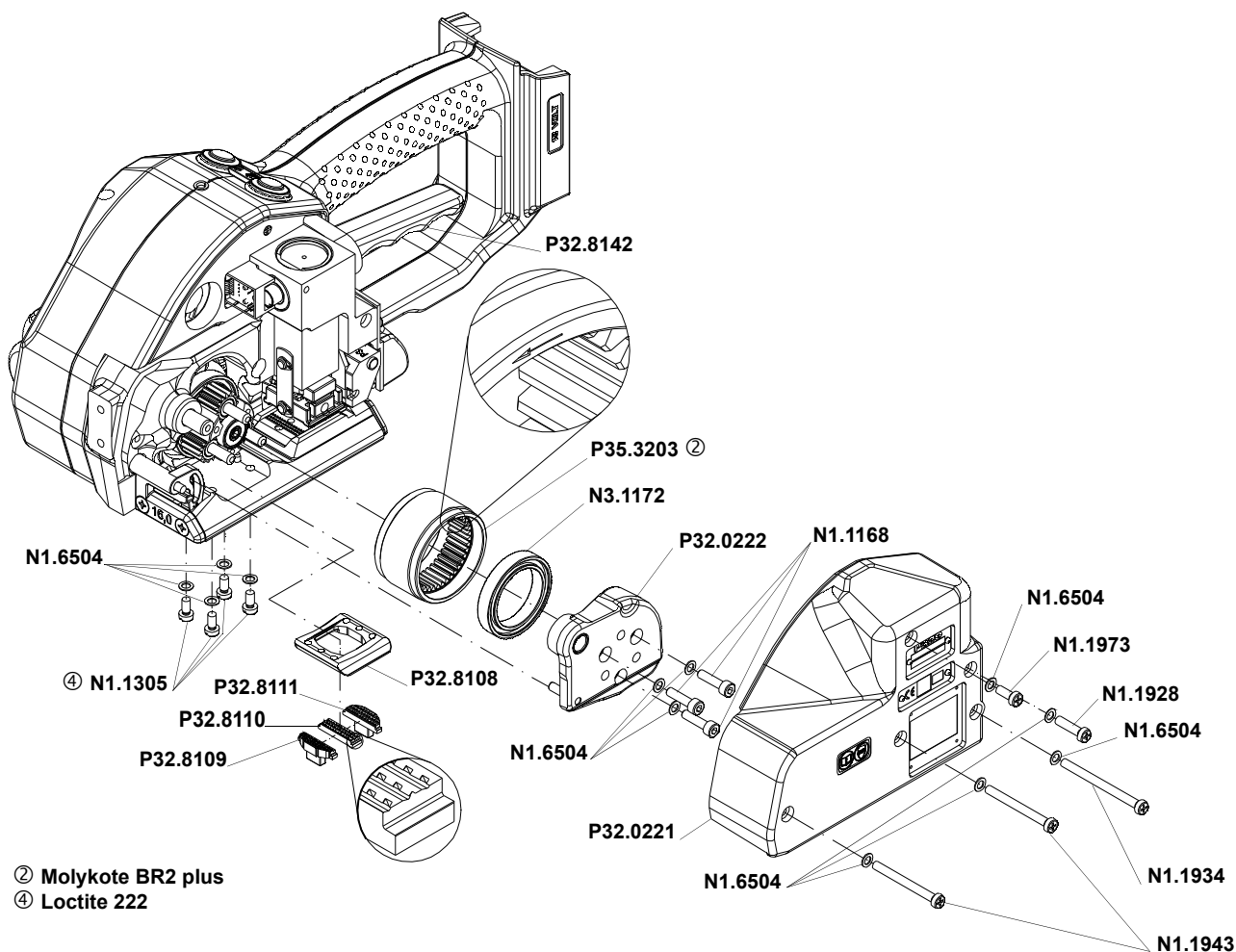

Assembling in opposite order.

Assembly advise

- Lubricate the internal tooting of the tensioning wheel with Molykote BR2 plus.
- Observe the position of the tensioning wheel. The direction of rotation of the tensioning wheel is marked at the front of the tensioning wheel (see drawing).
- Observe the position of the grippers (see drawing).
- Safe the screws N1.1305 with Loctite 222.

9.2 Exchange of cutter, welding stop gripper and welding gripper

Disassembling

- Unscrew cover P32.0221 and remove it;
- Unscrew end cover P32.0222 and remove it;
- Raise tensioning wheel P35.3203 by lifting the handle lever P32.8142;
- Pull off tensioning wheel together with bearing N3.1172 from the body.
- Remove cover P32.8195;
- **Don't** loosen screw N1.1553 at the coupler P35.0146.
- Disassemble the security ring N2.1121 from the coupler, remove the coupler;
- Pull out the centering sleeve P32.1710 from the guide case P35.3215, disassemble the guide case;
- Pull out the pressure spring N2.5237 with a screw driver from the cutter P35.3214;
- Remove the cutter from the driving pin P32.1032;
- Disassemble strap guide plate P32.8118;
- Disassemble the screws N1.1305, lift slightly the welding stop gripper P32.8107 and the steel insert P32.8106 and remove them from the tool;
- Push the steel insert without welding stop gripper under the welding gripper P32.1511 until it touches the parallel pin N2.2110;
- Turn welding gripper down, in case the welding gripper does not sit on the steel insert, put a piece of plastic strap underneath the steel insert;
- Disassemble the safety ring N2.1121 from the bolt P32.1028, remove the bolt from the welding gripper;
- Turn welding gripper up;
- Remove the thrust piece P32.1029 from the tool;
- Pull out the steel insert with care to right under the welding gripper;
- Lift the rocker P32.1024 behind the welding gripper with a screw driver, remove the welding gripper together with the ball cage P32.1027 and the balls N3.1702 from the tool.

- ① Mobilux EP2
- ② Molykote BR2 plus
- ④ Loctite 222
- ⑤ Klüber Isoflex Alltime SL2
- ⑥ Klüber Isoflex NBU 15

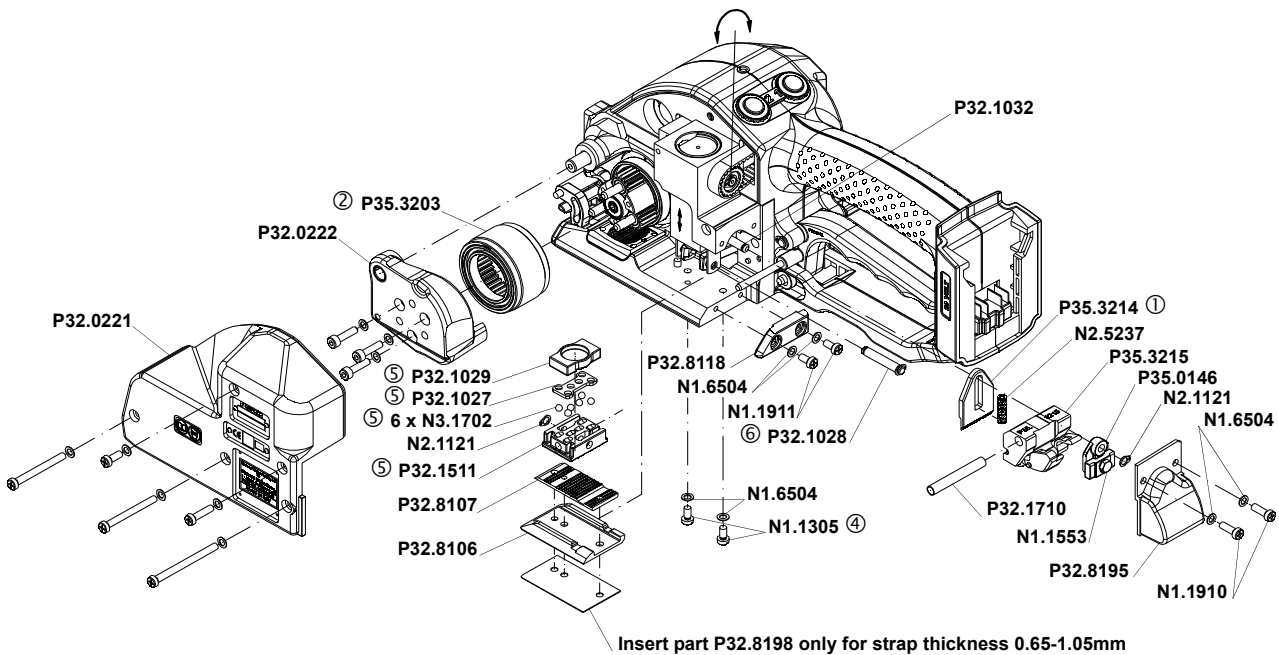

Assembling in opposite order.

Assembly advise

- During assembling move the strap guide plate P32.8118 downwards against the holding gripper.
- Pay attention to the fitting position of the cutter (see drawing).
- Safe the screws N1.1305 with Loctite 222.
- Lubricate the rocker and the bolt P32.1028 in the area of the welding gripper with Klüber Isoflex NBU 15.
- Lubricate the balls, ball cage and the running surface of the balls on the welding gripper with Klüber Isoflex Alltime SL2.
- Lubricate the cutter and the driver with Mobilux EP2.

9.3 Adjustment of the coupler

The coupler is adjusted in our works.

In case of replacing the seesaw lever, the coupler or the lever body, the coupler has to be readjusted.

Procedure as follows:

The battery is removed from the tool.

The coupler is fitted into the tool.

- Loosen screw N1.1553.
- Displace thrust piece, so that it touches the two seesaw levers without moving them.
- Re-tighten screw N1.1553.

Control:

The thrust piece must touch the seesaw levers (X1).

Both guide pins must sit on the welding stop gripper (X2).

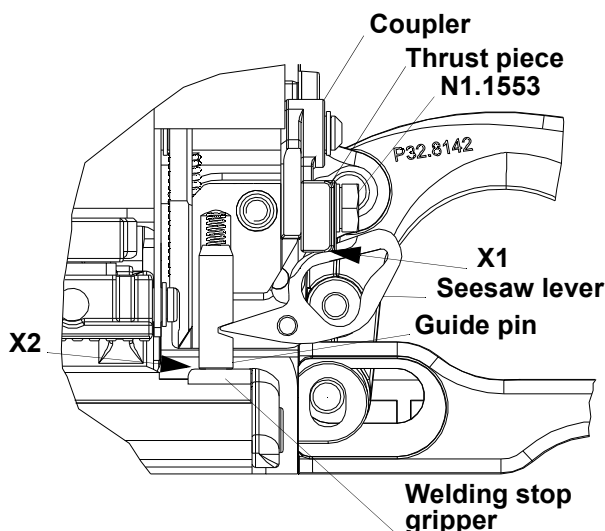

10 CLEANING

Clean strap gripping parts from strap abrasion regularly using compressed air.

Thus also the cover can be removed and with a suitable air gun air been blown on the welding elements.

Do not use any mechanical tool for cleaning.

When cleaning the surface of the tool do not use water or aggressive solvents!

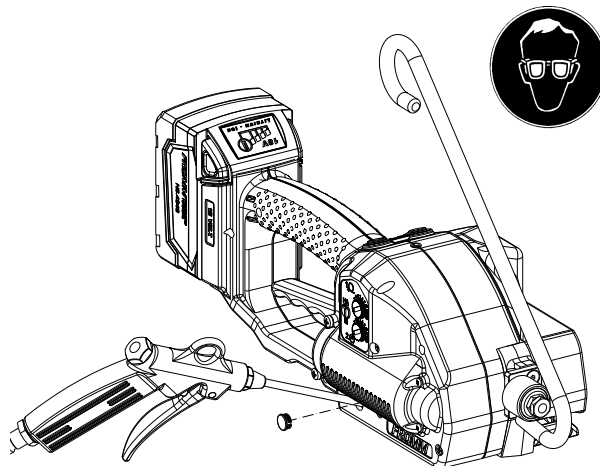

11 SERVICE

Servicing and repair work must only be carried out by authorized service centres.

If the tool breaks down or does no longer operate do not disassemble it. Send it fully assembled to the local service centre (see name and address on the rear page of this manual). Use original packing.

In order to prevent damages to the motor shaft the two needle free wheeling N3.4509 have to be replaced after maximum 80 000 strapping cycles.

The battery powered plastic strapping tool P329 is a high performance tool. We strongly recommend you to have it serviced by an authorized service shop after 12 months at the latest if used one shift per day. If used two or more shifts per day the tool has to be serviced after a shorter period of time.

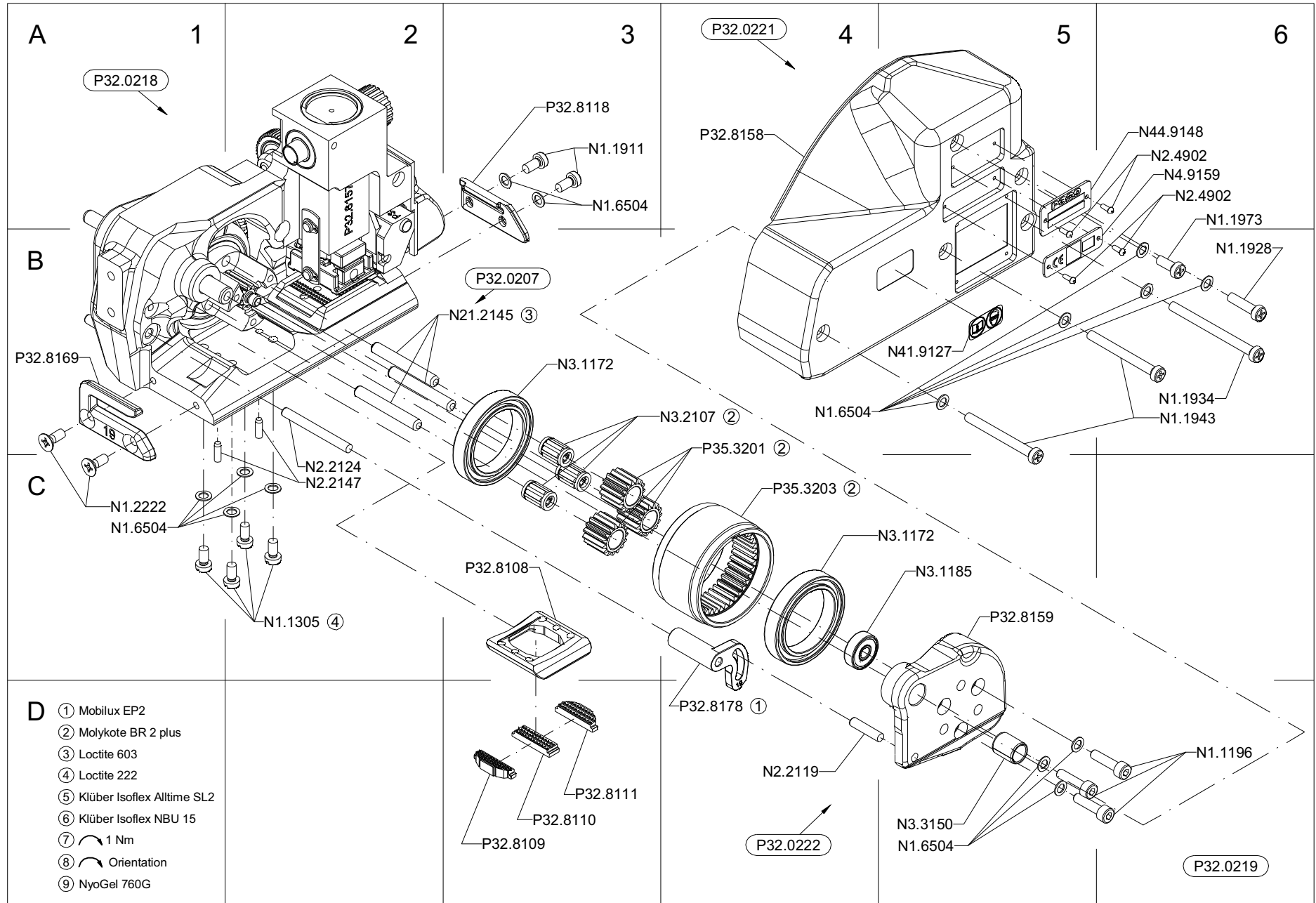

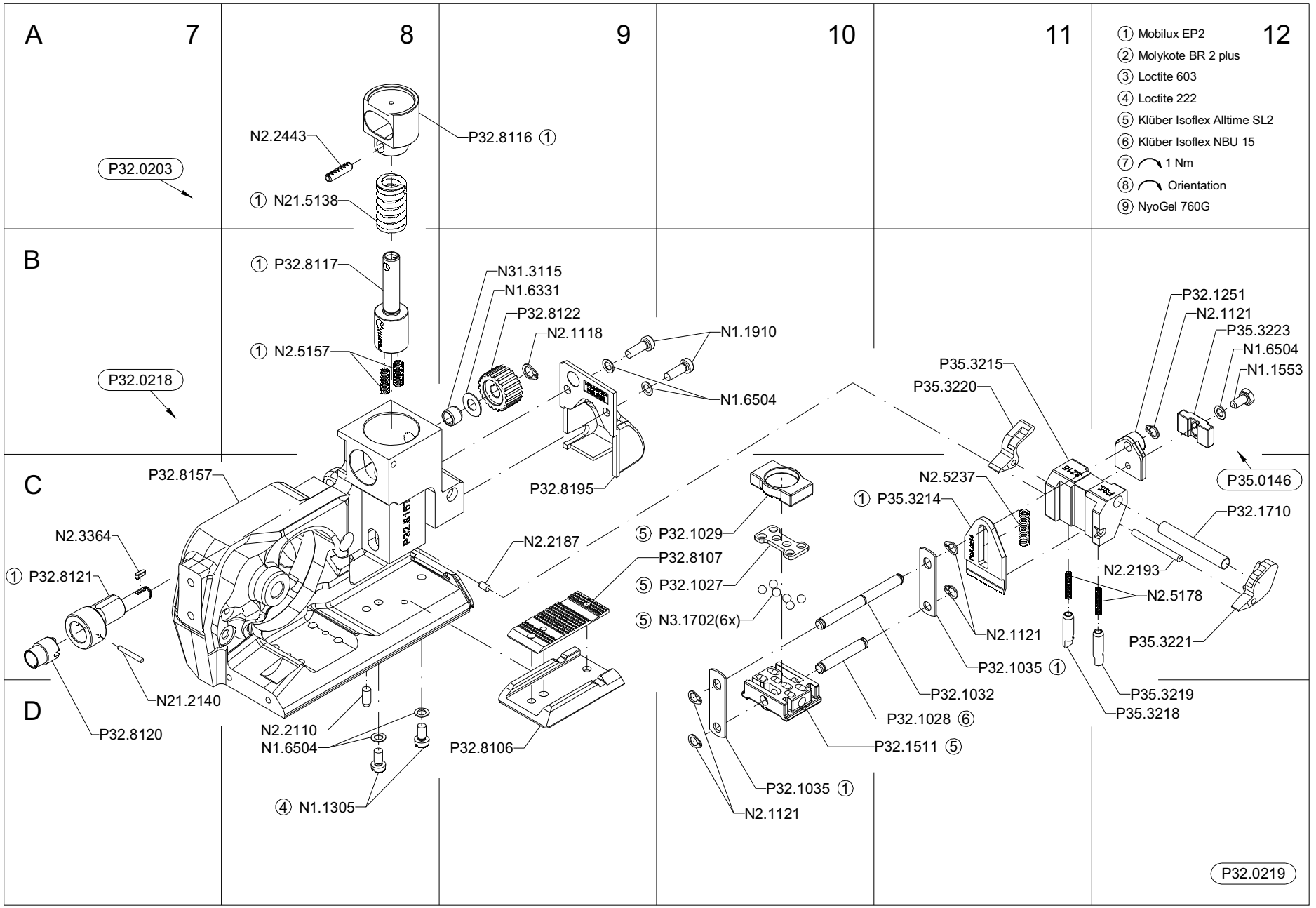

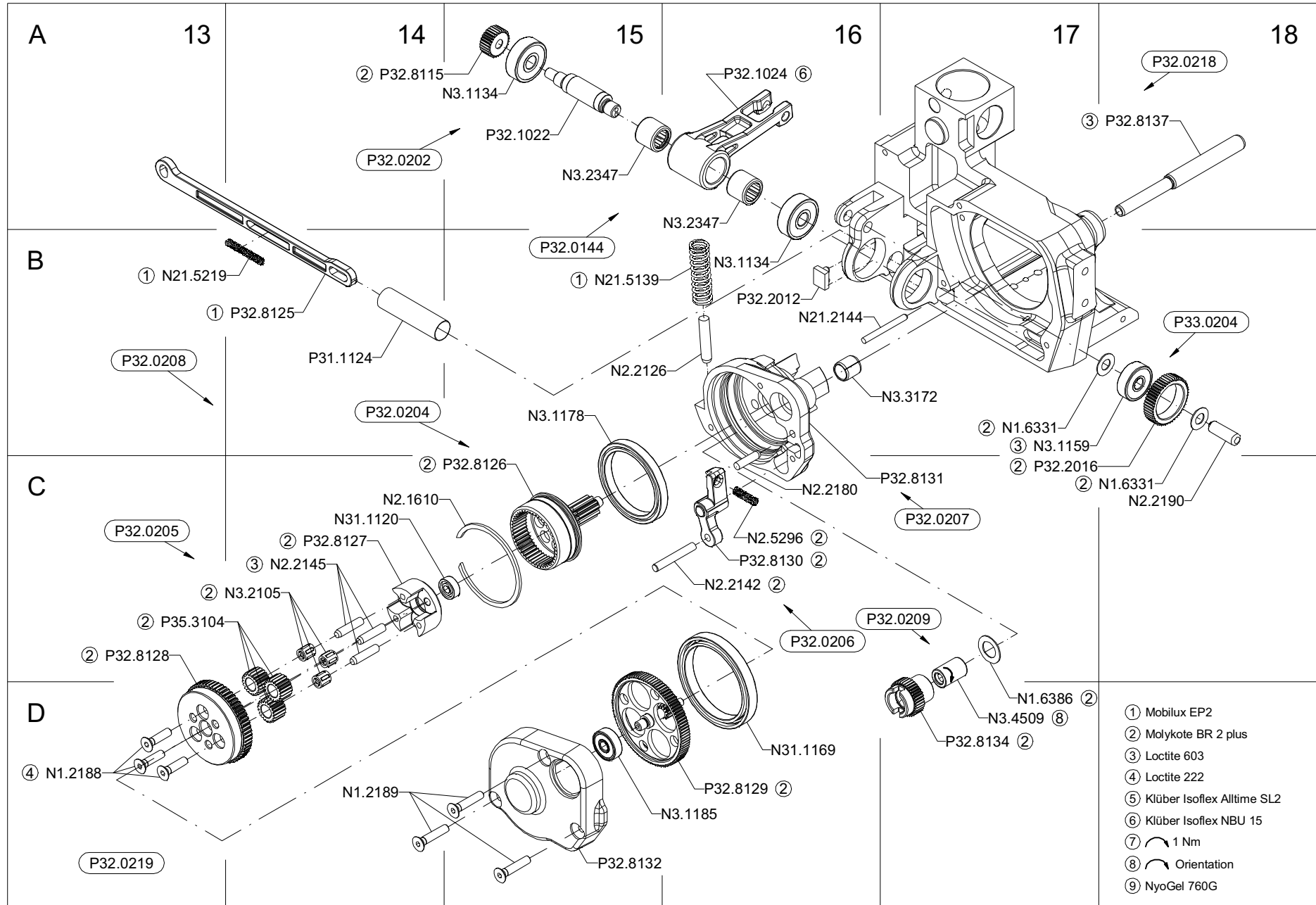

- ① Mobilux EP2
- ② Molykote BR 2 plus
- ③ Loctite 603
- ④ Loctite 222
- ⑤ Klüber Isoflex Alltime SL2
- ⑥ Klüber Isoflex NBU 15
- ⑦ 1 Nm
- ⑧ Orientation
- ⑨ NyoGel 760G

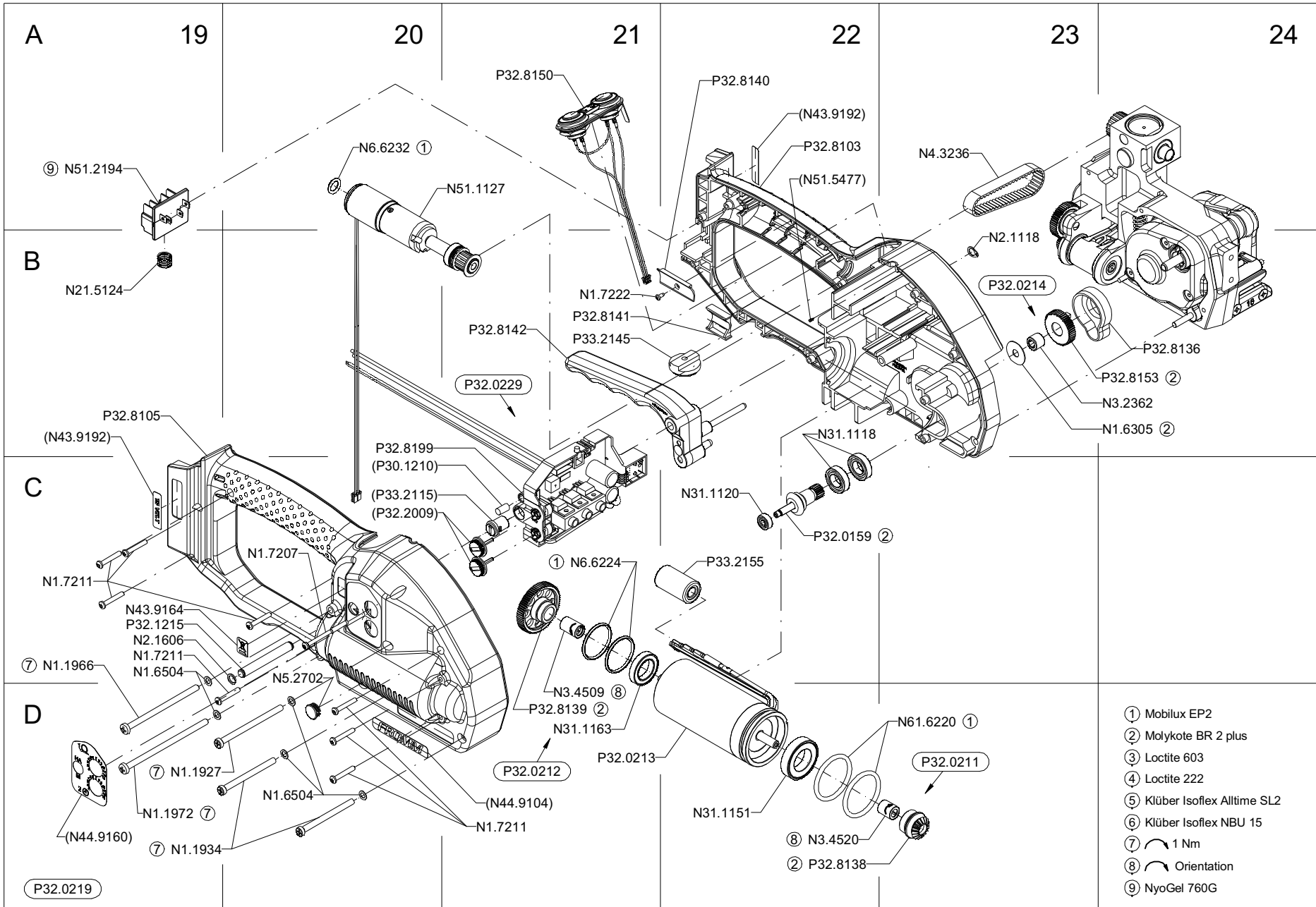

- ① Mobilux EP2
- ② Molykote BR 2 plus
- ③ Loctite 603
- ④ Loctite 222
- ⑤ Klüber Isoflex Alltime SL2
- ⑥ Klüber Isoflex NBU 15
- ⑦ 1 Nm
- ⑧ Orientation
- ⑨ NyoGel 760G

16 SPARE PARTS LIST 43.2533.01

43.2533.01	P329/19/1.06-1.35		P329.0001.01			13.05.14
Item-No.		in group	Pcs.	Description	Dimension	Field
N1.1196			3	SCREW	M4 X 16	D6
N1.1305			6	SCREW	M4 X 7.8	C2+
N1.1553		P35.0146	1	HEXAGON SCREW	M4 X 8	B12
N1.1910			2	FLAT HEAD SCREW	M4 X 12	B10
N1.1911			2	FLAT HEAD SCREW	M4 X 8	A3
N1.1927		P32.0219	1	FLAT HEAD SCREW	M4 X 60	D19
N1.1928			1	FLAT HEAD SCREW	M4 X 16	B6
N1.1934			1	FLAT HEAD SCREW	M4 X 50	B6
N1.1934		P32.0219	2	FLAT HEAD SCREW	M4 X 50	D19
N1.1943			2	FLAT HEAD SCREW	M4 X 40	B6
N1.1966		P32.0219	1	SCREW	M4 X 70	C19
N1.1972		P32.0219	1	SCREW	M4 X 80	D19
N1.1973			1	FLAT HEAD SCREW	M4 X 10	A6
N1.2188		P32.0205	3	COUNTERSUNK SCREW	M4 X 16	D13
N1.2189		P32.0208	3	COUNTERSUNK SCREW	M4 X 20	D14
N1.2222			2	COUNTERSUNK SCREW	M4 X 10	C1
N1.6305		P32.0219	1	SPACER WASHER	6 X 18 X 0.5	B24
N1.6331		P32.0219	3	SPACER WASHER	6 X 12 X 0.5	C18+
N1.6386		P32.0219	1	SPACER WASHER	9 X 15 X 0.50	D17
N1.6504			18	SAFETY WASHER	M4	B4+
N1.6504		P32.0219	5	SAFETY WASHER	M4	D20+
N1.6504		P35.0146	1	SAFETY WASHER	M4	B12
N1.7207		P32.0219	1	PT-SCREW	3 X 40	C20
N1.7211		P32.0219	8	PT-SCREW	3 X 20	C19+
N1.7222		P32.0219	1	PT-SCREW	2.2 X 5	B21
N2.1118		P32.0219	2	SECURITY RING	6	B9+
N2.1121			1	SECURITY RING	5	B12
N2.1121		P32.0219	4	SECURITY RING	5	C11+
N2.1606		P32.0219	1	SPRING RING	SW6	C19
N2.1610		P32.0208	1	SPRING RING	SB44	C14
N2.2110		P32.0218	1	PARALLEL PIN	4 m6 X 10	D8
N2.2119		P32.0222	1	PARALLEL PIN	4 m6 X 18	D4
N2.2124			1	PARALLEL PIN	4 m6 X 40	C2
N2.2126		P32.0207	1	PARALLEL PIN	5 m6 X 26	B15
N2.2142		P32.0206	1	PARALLEL PIN	4 m6 X 28	C16
N2.2145		P32.0205	3	PARALLEL PIN	4 h6 X 18	C14
N2.2147		P32.0218	2	PARALLEL PIN	3 m6 X 10	C2
N2.2180		P32.0208	1	PARALLEL PIN	4 m6 X 16	C16
N2.2187		P32.0218	1	PARALLEL PIN	3 m6 X 6	C9
N2.2190		P32.0219	1	PARALLEL PIN	6 h6 X 18	C18
N2.2193			1	PARALLEL PIN	3 m6 X 32	C12
N2.2443		P32.0203	1	DOWEL PIN	4 X 15	A8
N2.3364		P32.0219	1	FEATHER KEY	2 X 2 X 6	C7
N2.4902			2	HAMMER HEAD BOLT	1.85 X 4.76	A6
N2.4902		P32.0221	2	HAMMER HEAD BOLT	1.85 X 4.76	A6
N2.5157		P32.0219	2	PRESSURE SPRING	0.6 X 4.8 X 20/15.5	B8
N2.5178			2	PRESSURE SPRING	0.32X2.82X20.5/20.5	C12
N2.5237			1	PRESSURE SPRING	0.8 X 4.8 X 25/18.5	C11
N2.5296		P32.0208	1	PRESSURE SPRING	0.5 X 4 X 24/16.5	C16
N21.2140		P32.0219	1	PARALLEL PIN	2 m6 X 16	D7
N21.2144		P32.0219	1	PARALLEL PIN	3 h6 X 30	B16

[] = Group

* = Wearing parts

43.2533.01	P329/19/1.06-1.35		P329.0001.01			13.05.14
Item-No.		in group	Pcs.	Description	Dimension	Field
N21.2145		P32.0207	3	PARALLEL PIN	5 h6 X 37.3	B3
N21.5124		P32.0219	1	PRESSURE SPRING	0.9 X 10 X 15/5.5	B19
N21.5138		P32.0203	1	PRESSURE SPRING	2.5 X 14.2 X 33.5/7.5	A8
N21.5139		P32.0219	1	PRESSURE SPRING	1.25 X 9.8 X 45/14.5	B15
N21.5219		P32.0219	1	PRESSURE SPRING	0.43 X 3.6 X 32.9/27.5	B13
N3.1134		P32.0202	1	BALL BEARING	7 X 22 X7	A15
N3.1134		P32.0219	1	BALL BEARING	7 X 22 X7	B16
N3.1159		P33.0204	1	BALL BEARING	6 X 19 X 6	B17
N3.1172			2	BALL BEARING	30 X 42 X 7	B3+
N3.1178		P32.0204	1	BALL BEARING	35 X 44 X 5	B15
N3.1185			1	BALL BEARING	5 X 16 X 5	C5
N3.1185		P32.0208	1	BALL BEARING	5 X 16 X 5	D16
N3.1702		P32.0219	6	BALL	4 MM	C10
N3.2105		P32.0205	3	NEEDLE CAGE	K 4 X 7 X 7 TN	C14
N3.2107			3	NEEDLE CAGE	K 5 X 9 X 13 TN	B4
N3.2347		P32.0144	2	NEEDLE BUSH	10 X 14 X 12	A15+
N3.2362		P32.0214	1	NEEDLE BUSH	6 X 10 X 8	B24
N3.3150		P32.0222	1	SLIDE-BEARING	8 X 10 X 12	D5
N3.3172		P32.0207	1	SLIDE-BEARING	8 X 10 X 10	B17
N3.4509		P32.0209	1	NEEDLE FREE WHEELING	6 X 10 X 15	D17
N3.4509		P32.0212	1	NEEDLE FREE WHEELING	6 X 10 X 15	D21
N3.4520		P32.0211	1	FREE-WHEELING	6 X 10 X 12	D22
N31.1118		P32.0219	2	BALL BEARING	10 X 19 X 5	B22
N31.1120		P32.0205	1	BALL BEARING	4 X 11 X 4	C14
N31.1120		P32.0219	1	BALL BEARING	4 X 11 X 4	C22
N31.1151		P32.0219	1	BALL BEARING	17 X 30 X 7	D22
N31.1163		P32.0212	1	BALL BEARING	15 X 24 X 5	D21
N31.1169		P32.0205	1	BALL BEARING	40 X 50 X 6	D16
N31.3115		P32.0218	1	SLIDE-BEARING	6 X 8 X 6	B9
N4.3236		P32.0219	1	TOOTHED BELT	9 MM	A23
N4.9159		P32.0221	1	LABEL	<<CE>>	A6
N41.9127		P32.0221	1	ADHESIVE LABEL	20 X 10 X 0.1	B5
N43.9164		P32.8105	1	ADHESIVE LABEL	WEEE	C19
N43.9192		P32.8103	1	ADHESIVE LABEL	18 Volt	A22
N43.9192		P32.8105	1	ADHESIVE LABEL	18 Volt	B19
N44.9104		P32.8105	1	ADHESIVE LABEL	<<FROMM>>	D21
N44.9148			1	TYPE PLATE	<<P329>>	A6
N44.9160		P32.8105	1	ADHESIVE LABEL		D19
N5.2702			1	COVER		C20
N51.1127		P32.0219	1	GEAR MOTOR		A21
N51.2194		P32.0229	1	INSERTATION PART		A19
N51.5477		P32.8103	1	SPRING PIN		A22
N6.6224		P32.0219	2	O-RING	24 X 2	C21
N6.6232		P32.0219	1	O-RING	8 X 2	A20
N61.6220		P32.0219	2	O-RING	29.5 X 3	D23
P30.1210		P32.8199	1	HOLDING-DOWN CLAMP		C20
P31.1124		P32.0218	1	TUBE		B14
[P32.0144]		P32.0219	1	ROCKER		B15
P32.0159		P32.0219	1	PINION		C22
[P32.0202]		P32.0219	1	WELDING EXCENTRIC		A14
[P32.0203]		P32.0219	1	SPRING BOLT		A7
[P32.0204]		P32.0208	1	GEAR WHEEL		B14
[P32.0205]		P32.0208	1	IDLER STEP		C13

[] = Group

* = Wearing parts

43.2533.01	P329/19/1.06-1.35		P329.0001.01		13.05.14	
Item-No.		in group	Pcs.	Description	Dimension	Field
[P32.0206]		P32.0208	1	LEVER		C16
[P32.0207]		P32.0208	1	GEAR BODY		C17+
[P32.0208]		P32.0219	1	GEAR		B13
[P32.0209]		P32.0219	1	GEAR WHEEL		C17
[P32.0211]		P32.0219	1	CONICAL GEAR WHEEL		D23
[P32.0212]		P32.0219	1	GEAR WHEEL		D21
P32.0213	*	P32.0219	1	MOTOR		D21
[P32.0214]		P32.0219	1	GEAR WHEEL		B23
[P32.0218]		P32.0219	1	BODY		A1+
[P32.0219]			1	BASE MODEL		D6+
[P32.0221]			1	COVER		A4
[P32.0222]			1	END COVER		D4
[P32.0229]		P32.0219	1	CIRCUIT BOARD		B21
P32.1022		P32.0202	1	WELDING EXCENTRIC		A15
P32.1024		P32.0144	1	ROCKER		A16
P32.1027		P32.0219	1	BALL CAGE		C10
P32.1028		P32.0219	1	BOLT		D11
P32.1029		P32.0219	1	THRUST PIECE		C10
P32.1032		P32.0219	1	DRIVING PIN		D11
P32.1035		P32.0219	2	DRIVER		C11+
P32.1215		P32.0219	1	HANDLE SHAFT		C19
P32.1251		P35.0146	1	PUSHER		B12
P32.1511	*	P32.0219	1	WELDING GRIPPER		D11
P32.1710			1	CENTERING SLEEVE		C12
P32.2009		P32.8199	2	TURNING BUTTON		C20
P32.2012		P32.0219	1	GUIDE		B16
P32.2016		P33.0204	1	GEAR WHEEL		C17
[P32.8103]		P32.0219	1	MOTOR HOUSING		A22
[P32.8105]		P32.0219	1	MOTOR HOUSING		B19
P32.8106			1	STEEL INSERT		D9
P32.8107	*		1	WELDING STOP GRIPPER		C10
P32.8108			1	HOLDER		C3
P32.8109	*		1	GRIPPER		D3
P32.8110	*		1	GRIPPER		D3
P32.8111	*		1	GRIPPER		D3
P32.8115		P32.0202	1	PINION		A14
P32.8116		P32.0203	1	SPRING SLIDE		A9
P32.8117		P32.0203	1	SPRING BOLT		B8
P32.8118			1	STRAP GUIDE PLATE		A3
P32.8120		P32.0219	1	MAGNET		D7
P32.8121		P32.0219	1	ECCENTRIC SHAFT		C7
P32.8122		P32.0219	1	TOOTHED BELT PULLEY		B9
P32.8125		P32.0219	1	PUSHER		B14
P32.8126		P32.0204	1	GEAR WHEEL		C15
P32.8127		P32.0205	1	PLANET SHAFT		C14
P32.8128		P32.0205	1	GEAR WHEEL		C13
P32.8129		P32.0208	1	GEAR WHEEL		D16
P32.8130		P32.0206	1	LEVER		C16
P32.8131		P32.0207	1	GEAR BODY		C17
P32.8132		P32.0208	1	GEARING COVER		D15
P32.8134		P32.0209	1	GEAR WHEEL		D17
P32.8136		P32.0219	1	HOUSING		B24
P32.8137		P32.0218	1	SWIVEL SHAFT		A18

[] = Group

* = Wearing parts

43.2533.01	P329/19/1.06-1.35		P329.0001.01		13.05.14	
Item-No.		in group	Pcs.	Description	Dimension	Field
P32.8138		P32.0211	1	CONICAL GEAR WHEEL		D22
P32.8139		P32.0212	1	GEAR WHEEL		D21
P32.8140		P32.0219	1	RETAINER		A22
P32.8141		P32.0219	1	COVERING		B21
P32.8142		P32.0219	1	HANDLE LEVER		B21
P32.8150		P32.0219	1	TOUCH CONTACT-SWITCH		A21
P32.8153		P32.0214	1	GEAR WHEEL		B24
P32.8157		P32.0218	1	BODY		C7
P32.8158		P32.0221	1	COVER		A4
P32.8159		P32.0222	1	END COVER		C5
P32.8169			1	STRAP STOP		B1
P32.8178			1	STRAP GUIDE		D4
P32.8195			1	COVER		C9
[P32.8199]		P32.0229	1	CIRCUIT BOARD		B20
[P33.0204]		P32.0219	1	GEAR WHEEL		B18
P33.2115		P32.8199	1	TURNING BUTTON		C20
P33.2145		P32.0219	1	DISK		B21
P33.2155		P32.0219	1	DOWEL		C22
[P35.0146]			1	PUSHER		C12
P35.3104		P32.0205	3	IDLER GEAR		C13
P35.3201			3	IDLER GEAR		B4
P35.3203	*		1	TENSIONING WHEEL		C4
P35.3214	*		1	CUTTER		C11
P35.3215			1	GUIDE CASE		B11
P35.3218			1	GUIDE PIN		D12
P35.3219			1	GUIDE PIN		D12
P35.3220			1	SEESAW LEVER		B11
P35.3221			1	SEESAW LEVER		C12
P35.3223		P35.0146	1	THRUST PIECE		B12

[] = Group

* = Wearing parts